

Action code: AT FIRST OPPORTUNITY

## Safety Precautions

30-98 bore engines

SL2017-652/PRP  
October 2017

### Concerns

Owners and operators of MAN B&W two-stroke marine diesel engines.  
Type: MC/MC-C and ME/ME-C

### Summary

Updated Safety Precautions chapter.

Dear Sirs

As part of our continuous development, we have updated the Safety Precautions chapter in the Instruction Manual. You can find the new version enclosed with this service letter. Specific versions are also enclosed for gas-engines and liquid gas engines.

The general content of this chapter has been updated with a caution on loud noise peaks in case of abnormal running conditions. Furthermore, the content has been expanded with regard to guidance on lifting tools and procedures.

Please replace the chapter in the Instruction Manual and inform your crew of the safety update.

Correct operation and maintenance of the main engine are crucial points for obtaining an optimum safety in the engine room.

Electronic versions of the updated safety precautions can be viewed and printed from the links below:

- ME-B-LGI (master manual)
- ME-C-GI (master manual)
- ME-C/ME-B (master manual)
- MC-MC-C/ME/ME-C (classic edition)

If you have any questions regarding the content of this Service Letter, please contact our Maintenance Tools department, via e-mail [LEE3@mandieselturbo.com](mailto:LEE3@mandieselturbo.com).

Yours faithfully



**Mikael C Jensen**  
Vice president  
Engineering

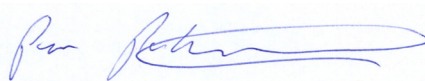

**Per Pallisgaard**  
Manager  
Product safety



Enclosures

**Head office (& postal address)**  
**MAN Diesel & Turbo**  
Tegholmegade 41  
2450 Copenhagen SV  
Denmark  
Phone: +45 33 85 11 00  
Fax: +45 33 85 10 30  
[info-cph@mandieselturbo.com](mailto:info-cph@mandieselturbo.com)  
[www.mandieselturbo.com](http://www.mandieselturbo.com)

**PrimeServ**  
Tegholmegade 41  
2450 Copenhagen SV  
Denmark  
Phone: +45 33 85 11 00  
Fax: +45 33 85 10 49  
[PrimeServ-cph@mandieselturbo.com](mailto:PrimeServ-cph@mandieselturbo.com)

**Production**  
Tegholmegade 35  
2450 Copenhagen SV  
Denmark  
Phone: +45 33 85 11 00  
Fax: +45 33 85 10 17  
[manufacturing-dk@mandieselturbo.com](mailto:manufacturing-dk@mandieselturbo.com)

**Forwarding & Receiving**  
Tegholmegade 35  
2450 Copenhagen SV  
Denmark  
Phone: +45 33 85 11 00  
Fax: +45 33 85 10 16  
[shipping-cph@mandieselturbo.com](mailto:shipping-cph@mandieselturbo.com)

**MAN Diesel & Turbo**  
Branch of MAN Diesel & Turbo SE,  
Germany  
CVR No.: 31611792  
Head office: Tegholmegade 41  
2450 Copenhagen SV, Denmark  
German Reg.No.: HRB 22056  
Amtsgericht Augsburg

## General

*Correct operation and maintenance, which is the aim of this book, are crucial points for obtaining optimum safety in the engine room. The general measures mentioned here should therefore be routine practice for the entire engine crew.*

---



## Maintenance

- Read and follow all instructions given in work cards.
  - Only use original spare parts.
  - Only use appropriate tools.
  - Always inspect the engine when maintenance work is completed.
-

## Engine Room Staff

Operation and maintenance of MAN B&W engines is to be carried out exclusively by qualified professional personnel.



Minimum personal safety equipment requirements:

1. Safety shoes
2. Hearing protection, *see caution.*
3. Boiler suit or other similar protective wear

 **CAUTION**



### Running engine

In case of abnormal condition during engine running, loud noise peak can occur.

Both earplugs and earmuffs must be used, in combination.

## Special Dangers

---



A number of situations may lead to risk of serious injury to the body. The following recommendations must always be observed:

- Keep clear of the space below a crane with load.
  - Before opening of cocks, always observe which way liquids, gases or flames will move, and keep clear.
  - Dismantling of parts may cause the release of springs.
  - Removal of plugs may cause the release of pressurized fluids or gasses.
  - Do not stand near turbochargers in case of any abnormal running.
  - Do not stand near crankcase doors or relief valves – nor in corridors near doors to the engine room – if an alarm sets off for oil mist, high lube oil temperature, no piston cooling oil flow, or scavenge box fire.  
*See also Chapter 704.*
- 

## Turning Gear

Before engaging the turning gear, ensure that the starting air supply is shut off, the main starting and slow turning valves are blocked, and that the indicator cocks are open.

When the turning gear is engaged, check that the indicator lamp “Turning gear in” has switched on.

The turning gear remote control is a critical device and should always be kept in optimal working condition. Any fault in the device or cable must be rectified before use.

*When operating the turning gear it is important to note the following:*

The turning gear must be operated by the remote control and only by the person working on the engine.

Warnings must be given before each turning. Operation of the turning gear from the switchboard must not take place while maintenance work is in progress inside the engine.

Block the switch or place a “Do not touch” sign.

## Entering the Crankcase, Cylinder Liner or Scavenge Air Receiver

---



Always ensure that the turning gear is engaged and the brake is active, to prevent external forces or unbalance of the crankshaft from turning the crankshaft.

---

Check that the starting air supply to the engine and the starting air distributor is shut off and that the main starting valve is locked.

In case of oil mist alarm, precautions must be taken before opening the doors to the crankcase (*see section 704-02*). Before entering, ventilate the crankcase for about 30 minutes after stopping the engine.

Work inside the crankcase requires the use of safety harness and fall arrester equipment.

Work inside the crankcase is as minimum a two-man job, and good communication must be maintained at all times.

The turning gear must always be operated exclusively by the person(s) who enters the crankcase, cylinder liner or scavenge air receiver.

## Cleanliness

The engine and engine room should always be kept clean and tidy.

Oily rags must never be left around the engine room spaces as they are highly flammable and slippery.

Remove any oil spill immediately.

If there is a risk of grit or sand blowing into the engine room, stop the ventilation and close the ventilating ducts, skylights and engine room doors.

Welding or other work that causes spreading of grit and/or swarf must not be carried out near the engine unless it is closed or protected and the turbocharger air intake filters are covered.

The exterior of the engine should be kept clean, and the paintwork maintained, so that leakages can be easily detected.

## Fire



Keep the areas around the relief valves free of oil, grease, etc. to prevent the risk of fire caused by the emitted hot air/gas if the relief valves open.

---

Do not weld or use naked lights in the engine room until it has been ascertained that no explosive gases, vapour or liquids are present.

If the crankcase is opened before the engine has cooled down, welding and the use of naked flames will result in the risk of explosions and fire. The same applies to inspection of oil tanks and of the spaces below the floor.

Attention is furthermore drawn to the danger of fire when using paint and solvents with a low flash point. Porous insulating material, soaked with oil from leakages, is flammable and should be renewed.

*See also sections 704-01, 02 and 'Sealing Materials' in this section.*

## Order/Tidiness

Hand tools should be securely fastened and placed on easily accessible tool panels. Special tools should be securely fastened close to the area of use in the engine room.

Do not store engine parts on engine galleries while the engine is running.

Do not leave major objects unfastened, and keep floor and passages clear at all times.

## Spares

Large spare parts should, as far as possible, be placed near the area of use, well secured and accessible by crane.

All spares should be protected against corrosion and mechanical damage. The stock should be checked at intervals and replenished in good time.

## Lighting

Ample working light should be permanently installed at appropriate places in the engine room spaces, and portable working light should be obtainable everywhere. 24v safety lamps must be available for use inside the engine.

## Harmful Materials

Always follow the manufacturer's specific instructions, i.e. the material safety data sheet (MSDS).

Use protective gloves, goggles, breathing mask and any other recommended protective gear stated in the material safety data sheet.

Read the material safety data sheet regarding first aid measures in the event of skin contact.

When handling harmful materials it is important to ensure proper ventilation and shielding if needed.

In the event of leaks or spillage, spread binding agents immediately. Dispose of the binding agents according to the material safety data sheet.

## Guidelines for all lifting tools

Prior to any use lifting tools must be visual inspected for cracks, corrosion, excessive wear, loose fasteners, deformations and damages.

Unidentified or damaged tools and tools not clearly marked with Safe Working Load (SWL) or Work Load Limit (WLL) must not be used. Plan the lift and determine weight of the load and center of gravity. Use designated lifting points if any and determine which lifting tool and attachment is to be used.

Plan the movement and landing of the load and safe disconnecting of lifting tools.

Beware of the sling angles:

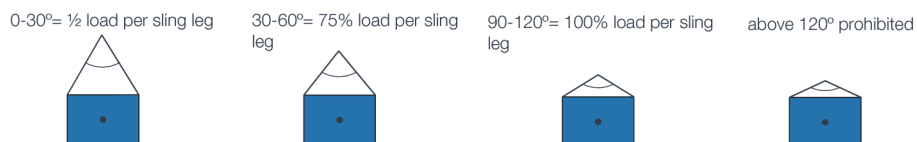

Tie down the load to avoid sliding and danger of falling objects and cover sharp edges on the load to avoid cutting wires, ropes and slings.



Plan lifting of engine components through all steps of the lifting procedure.

 **WARNING**

**Never work or stay under a suspended load !**

**Synthetic web slings**

Be aware of max. load in accordance to table.

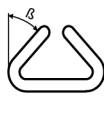
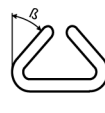
Designation	WLL	Color code	Straight Pull	Tied Pull	Parallel Pull	0°- 45°	45°- 60°
							
	t		kg	kg	kg	kg	kg
002	2	Green	2000	1600	4000	2800	2000
003	3	Yellow	3000	2400	6000	4200	3000
004	4	Grey	4000	3200	8000	5600	4000
006	6	Brown	6000	4800	12000	8400	6000
008	8	Blue	8000	6400	16000	11200	8000
010	10	Orange	10000	8000	20000	14000	10000

**Shackles**

Screwpins to be tightened to full contact – use hand tools. Bolt and nut type to be secured with cutter pin.

**Eye screw / Eye nut**

Tighten to full contact without any gap - use hand tools. Be aware of loading direction. Lateral loading is prohibited in all cases !

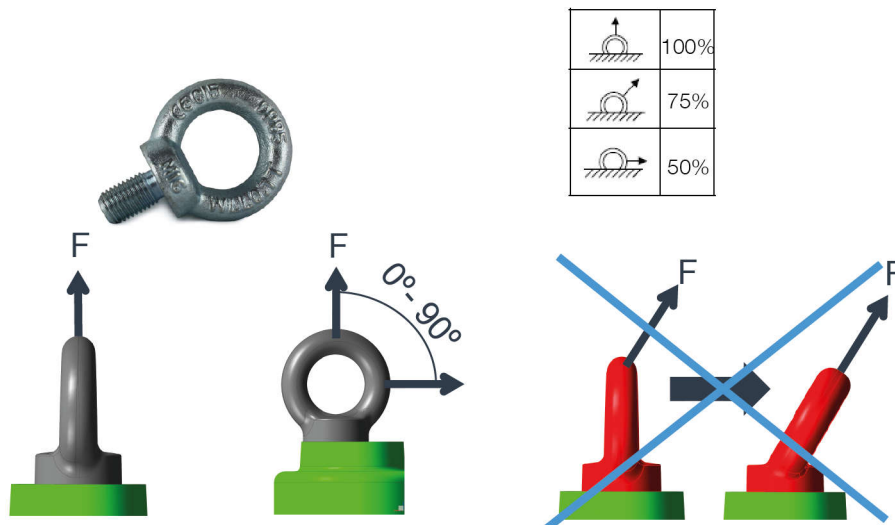

**Hooks**

Only hooks with safety latches are allowed for lifting.



**Chain tackles**

Be aware of lifting angle.

**Working Air**

Use of working air requires safety goggles and gloves.

Avoid blowing pressurised air directly at any part of the body, especially exposed skin, eyes and ears.

**Sealing Materials**

Use gloves made of neoprene or PVC when removing O-rings and other rubber/plastic-based sealing materials which have been subjected to abnormally high temperatures.

**Hot Surfaces**

Beware of hot surfaces and always use gloves.

**Alarms**

It is important that all alarms lead to prompt investigation and remedy of the error. No alarm is insignificant. The most serious alarms are equipped with slow-down and/or shut-down functions. It is therefore important that all engine operation personnel are well-trained in the use and importance of the alarm system.

### Subsuppliers and External Equipment

Check the special instructions concerning subsupplier delivery and external equipment for specific warnings!

### Safety Notes

---



This warning is used when an operation, procedure, or use may cause personal injury or loss of life.

---

---



This warning is used when an operation, procedure, or use may cause a latently dangerous state of personal injury or loss of life.

---

---



This warning is used when an operation, procedure, or use may cause damage to or destruction of equipment and a injury.

---

---



This warning is used when an operation, procedure, or use may cause damage to or destruction of equipment.

---

## 1. Safety Precautions at Maintenance

Before carrying out maintenance work, stop and block the engine according to the safety precautions given on the specific Data Page.

Other safety precautions than listed below may apply.

### SAFETY PRECAUTIONS



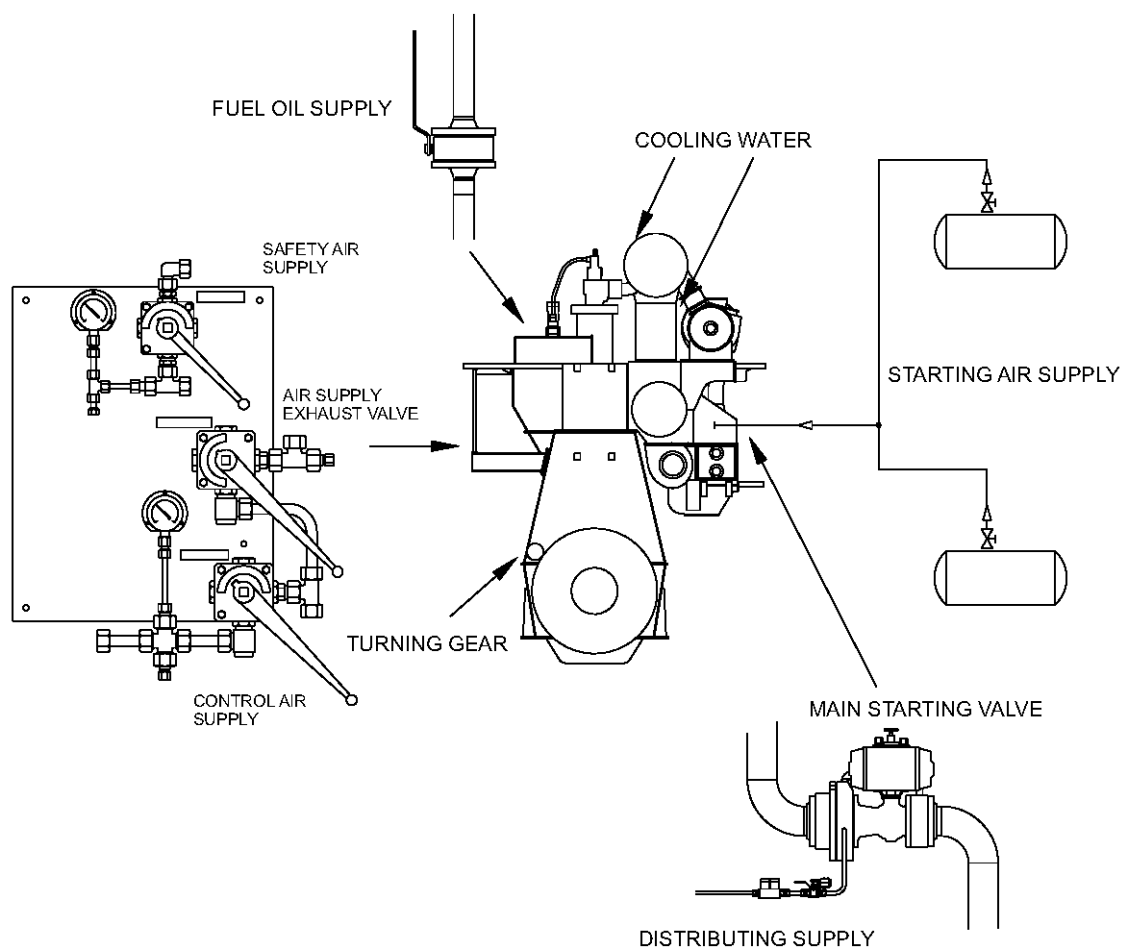

















X	Stopped engine
X	Shut off starting air supply – <i>At starting air receiver</i>
X	Block the main starting valve
X	Shut off starting air distributor/distributing system supply
X	Shut off safety air supply – <i>Not ME-engines</i>
X	Shut off control air supply
X	Shut off air supply to exhaust valve – <i>Only with stopped lubricating oil pumps</i>
X	Engage turning gear
X	Shut off cooling water
X	Shut off fuel oil
X	Stop lubricating oil supply
X	Lock the turbocharger rotors





*The drawing gives the approximate location of the valves concerned*

**Data Sheet Signs**

Data sheets may include warning signs for special dangers that could arise in connection with the maintenance procedures.

Warning signs		Mandatory action signs	
General warning sign		General mandatory action sign	
Explosive material		Wear ear protection	
Drop (fall)		Wear eye protection	
Slippery surface		Wear safety footwear	
Electricity		Wear protective gloves	
Overhead load		Wear face shield	
Hot surface		Wear head protection	
Crushing		Wear mask	
Overhead obstacle		Wear respiratory protection	
Flammable		Wear safety harness	
Crushing of hands		Disconnect before carrying out maintenance	
Pressurised cylinder		Wear antistatic footwear	

Warning signs		Mandatory action signs	
Pressurised device		Use gas detector	
Falling objects			

## General

*Correct operation and maintenance, which is the aim of this book, are crucial points for obtaining optimum safety in the engine room. The general measures mentioned here should therefore be routine practice for the entire engine crew.*

### WARNING

#### Maintenance

- Read and follow all instructions given in work cards.
- Only use original spare parts.
- Only use appropriate tools.
- Always inspect the engine when maintenance work is completed.

## Engine Room Staff

Operation and maintenance of MAN B&W engines is to be carried out exclusively by qualified professional personnel.

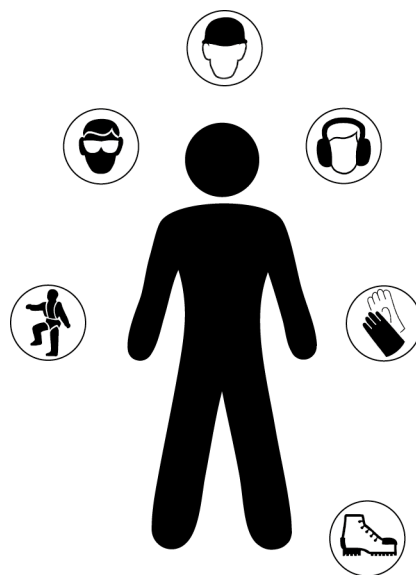

Minimum personal safety equipment requirements:

1. Safety shoes
2. Hearing protection, *see caution.*
3. Boiler suit or other similar protective wear

### CAUTION

#### Running engine

In case of abnormal condition during engine running, loud noise peak can occur.



Both earplugs and earmuffs must be used, in combination.

## Special Dangers



A number of situations may lead to risk of serious injury to the body. The following recommendations must always be observed:

- Keep clear of the space below a crane with load.
- Before opening of cocks, always observe which way liquids, gases or flames will move, and keep clear.
- Dismantling of parts may cause the release of springs.
- Removal of plugs may cause the release of pressurized fluids or gasses.
- Do not stand near turbochargers in case of any abnormal running.
- Do not stand near crankcase doors or relief valves – nor in corridors near doors to the engine room – if an alarm sets off for oil mist, high lube oil temperature, no piston cooling oil flow, or scavenge box fire.  
*See description 6645-0290 and 6645-0300.*

## Turning Gear

Before engaging the turning gear, ensure that the starting air supply is shut off, the main starting and slow turning valves are blocked, and that the indicator cocks are open.

When the turning gear is engaged, check that the indicator lamp “Turning gear in” has switched on.

The turning gear remote control is a critical device and should always be kept in optimal working condition. Any fault in the device or cable must be rectified before use.

*When operating the turning gear it is important to note the following:*

The turning gear must be operated by the remote control and only by the person working on the engine.

Warnings must be given before each turning. Operation of the turning gear from the switchboard must not take place while maintenance work is in progress inside the engine.

Block the switch or place a “Do not touch” sign.

## Entering the Crankcase, Cylinder Liner or Scavenge Air Receiver



### WARNING

Always ensure that the turning gear is engaged and the brake is active, to prevent external forces or unbalance of the crankshaft from turning the crankshaft.

Check that the starting air supply to the engine and the starting air distributor is shut off and that the main starting valve is locked.

Before entering the scavenge air receiver, shut off and block the auxiliary blower main starting panel.

In case of oil mist alarm, precautions must be taken before opening the doors to the crankcase (*see description 6645-0300*). Before entering, ventilate the crankcase for about 30 minutes after stopping the engine.

Work inside the crankcase requires the use of safety harness and fall arrester equipment.

Work inside the crankcase is as minimum a two-man job, and good communication must be maintained at all times.

The turning gear must always be operated exclusively by the person(s) who enters the crankcase, cylinder liner or scavenge air receiver.

## Cleanliness

The engine and engine room should always be kept clean and tidy.

Oily rags must never be left around the engine room spaces as they are highly flammable and slippery.

Remove any oil spill immediately.

If there is a risk of grit or sand blowing into the engine room, stop the ventilation and close the ventilating ducts, skylights and engine room doors.

Welding or other work that causes spreading of grit and/or swarf must not be carried out near the engine unless it is closed or protected and the turbocharger air intake filters are covered.

The exterior of the engine should be kept clean, and the paintwork maintained, so that leakages can be easily detected.



## Fire



Keep the areas around the relief valves free of oil, grease, etc. to prevent the risk of fire caused by the emitted hot air/gas if the relief valves open.

Do not weld or use naked lights in the engine room until it has been ascertained that no explosive gases, vapour or liquids are present.

If the crankcase is opened before the engine has cooled down, welding and the use of naked flames will result in the risk of explosions and fire. The same applies to inspection of oil tanks and of the spaces below the floor.

Attention is furthermore drawn to the danger of fire when using paint and solvents with a low flash point. Porous insulating material, soaked with oil from leakages, is flammable and should be renewed.

*See also description 6645-0290, -0300 and 'Sealing Materials' in this description.*

## Order/Tidiness

Hand tools should be securely fastened and placed on easily accessible tool panels. Special tools should be securely fastened close to the area of use in the engine room.

Do not store engine parts on engine galleries while the engine is running.

Do not leave major objects unfastened, and keep floor and passages clear at all times.

## Spares

Large spare parts should, as far as possible, be placed near the area of use, well secured and accessible by crane.

All spares should be protected against corrosion and mechanical damage. The stock should be checked at intervals and replenished in good time.

## Lighting

Ample working light should be permanently installed at appropriate places in the engine room spaces, and portable working light should be obtainable everywhere. 24v safety lamps must be available for use inside the engine.

### Harmful Materials

Always follow the manufacturer's specific instructions, i.e. the material safety data sheet (MSDS).

Use protective gloves, goggles, breathing mask and any other recommended protective gear stated in the material safety data sheet.

Read the material safety data sheet regarding first aid measures in the event of skin contact.

When handling harmful materials it is important to ensure proper ventilation and shielding if needed.

In the event of leaks or spillage, spread binding agents immediately. Dispose of the binding agents according to the material safety data sheet.

### Guidelines for all lifting tools

Prior to any use lifting tools must be visual inspected for cracks, corrosion, excessive wear, loose fasteners, deformations and damages.

Unidentified or damaged tools and tools not clearly marked with Safe Working Load (SWL) or Work Load Limit (WLL) must not be used. Plan the lift and determine weight of the load and center of gravity. Use designated lifting points if any and determine which lifting tool and attachment is to be used.

Plan the movement and landing of the load and safe disconnecting of lifting tools.

Beware of the sling angles:

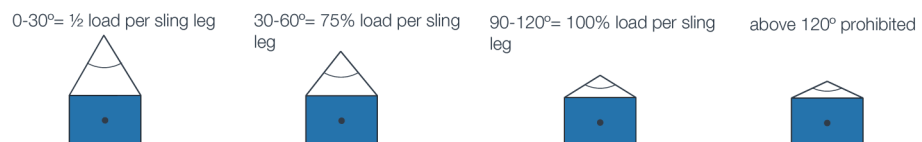

Tie down the load to avoid sliding and danger of falling objects and cover sharp edges on the load to avoid cutting wires, ropes and slings. Plan lifting of engine components through all steps of the lifting procedure.



**Never work or stay under a suspended load !**

**Synthetic web slings**

Be aware of max. load in accordance to table.

Designation	WLL	Color code	Straight Pull	Tied Pull	Parallel Pull	0°- 45°	45°- 60°
	t		kg	kg	kg	kg	kg
002	2	Green	2000	1600	4000	2800	2000
003	3	Yellow	3000	2400	6000	4200	3000
004	4	Grey	4000	3200	8000	5600	4000
006	6	Brown	6000	4800	12000	8400	6000
008	8	Blue	8000	6400	16000	11200	8000
010	10	Orange	10000	8000	20000	14000	10000

**Shackles**

Screwpins to be tightened to full contact – use hand tools. Bolt and nut type to be secured with cutter pin.

**Eye screw / Eye nut**

Tighten to full contact without any gap - use hand tools. Be aware of loading direction. **Lateral loading is prohibited in all cases !**

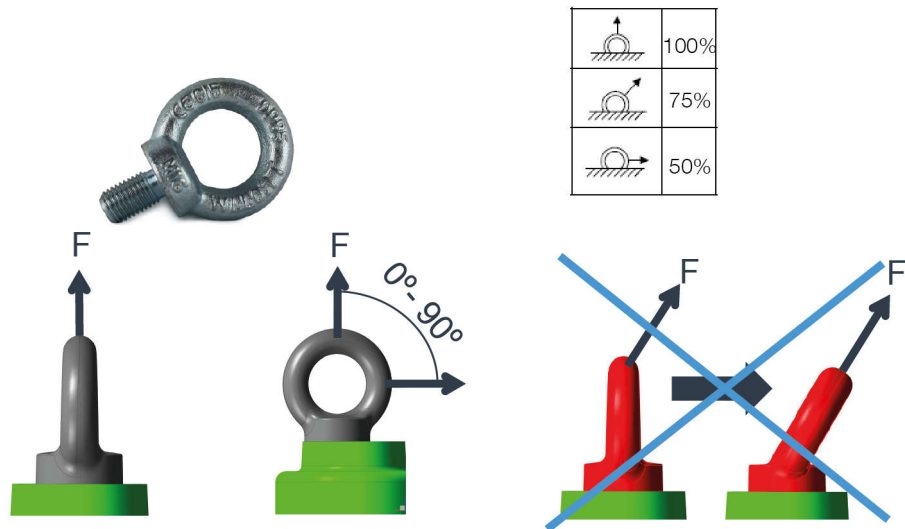

**Hooks**

Only hooks with safety latches are allowed for lifting.

### Chain tackles

Be aware of lifting angle.



## Working Air

Use of working air requires safety goggles and gloves.

Avoid blowing pressurised air directly at any part of the body, especially exposed skin, eyes and ears.

## Sealing Materials

Use gloves made of neoprene or PVC when removing O-rings and other rubber/plastic-based sealing materials which have been subjected to abnormally high temperatures.

## Hot Surfaces

Beware of hot surfaces and always use gloves.

## Splash guard

It is required that fuel oil and lubrication oil lines and flanged connections must be screened or otherwise suitably protected to avoid oil onto hot surfaces, air intakes, electrical installations or other sources of ignition.

Splash guard removed in connection with maintenance or repair work must be reinstalled again when the work has been carried out.

## Alarms

It is important that all alarms lead to prompt investigation and remedy of the error. No alarm is insignificant. The most serious alarms are equipped with slow-down and/or shut-down functions. It is therefore important that all engine operation personnel are well-trained in the use and importance of the alarm system.

## Second fuel Leakage Detection and Tightness Test



- It is **not** allowed to detect for second fuel leakages by unscrewing the detection plugs while the system is pressurised with second fuel.
- Detection is **only** allowed after purging with nitrogen several times and subsequently using an oxygen sensor while the system is pressurised with nitrogen.
- All personnel not relevant to the tightness test is to be evacuated from the test area.
- If the engine is stopped the leakage detection should be performed **with open indicator cocks and disengaged turning gear** in order to avoid unintentional engine turning.  
*See description 4245-0050.*

## Second fuel Related Maintenance Work

Pressure test the system after any kind of maintenance on parts related to the second fuel system.

*See description 4245-0050 - 'Pipe verification test'.*

For handling of second fuel components, *see description 0545-0200 'Fuel safety precautions'.*

## Subsuppliers and External Equipment

Check the special instructions concerning subsupplier delivery and external equipment for specific warnings!

## Safety Notes



**DANGER**

This warning is used when an operation, procedure, or use may cause personal injury or loss of life.



**WARNING**

This warning is used when an operation, procedure, or use may cause a latently dangerous state of personal injury or loss of life.



**CAUTION**

This warning is used when an operation, procedure, or use may cause damage to or destruction of equipment and a injury.



**NOTICE**

This warning is used when an operation, procedure, or use may cause damage to or destruction of equipment.

## Safety Precautions at Maintenance

Before carrying out maintenance work, stop and block the engine according to the safety precautions given on the specific work card.

Other safety precautions than listed below may apply.

<input type="checkbox"/>	Stop the Engine
<input type="checkbox"/>	Close the manual shut-off valve on the second fuel valve train
<input type="checkbox"/>	Shut off control air supply to the second fuel valve train
<input type="checkbox"/>	Block hydraulic oil supply to the second fuel/hydraulic control block
<input type="checkbox"/>	Depressurise the second fuel/hydraulic control block
<input type="checkbox"/>	Shut down cooling/sealing oil unit
<input type="checkbox"/>	Shut off starting air supply - At starting air receiver
<input type="checkbox"/>	Block the main starting valve
<input type="checkbox"/>	Shut off starting air distributor/distributing system supply
<input type="checkbox"/>	Shut off control air supply
<input type="checkbox"/>	Shut off air supply to exhaust valve - Only with stopped lub. oil pumps
<input type="checkbox"/>	Engage turning gear
<input type="checkbox"/>	Shut off cooling water
<input type="checkbox"/>	Shut off fuel oil
<input type="checkbox"/>	Stop lubricating oil supply
<input type="checkbox"/>	Shut down hydraulic power supply
<input type="checkbox"/>	Shut off and block the auxiliary blowers

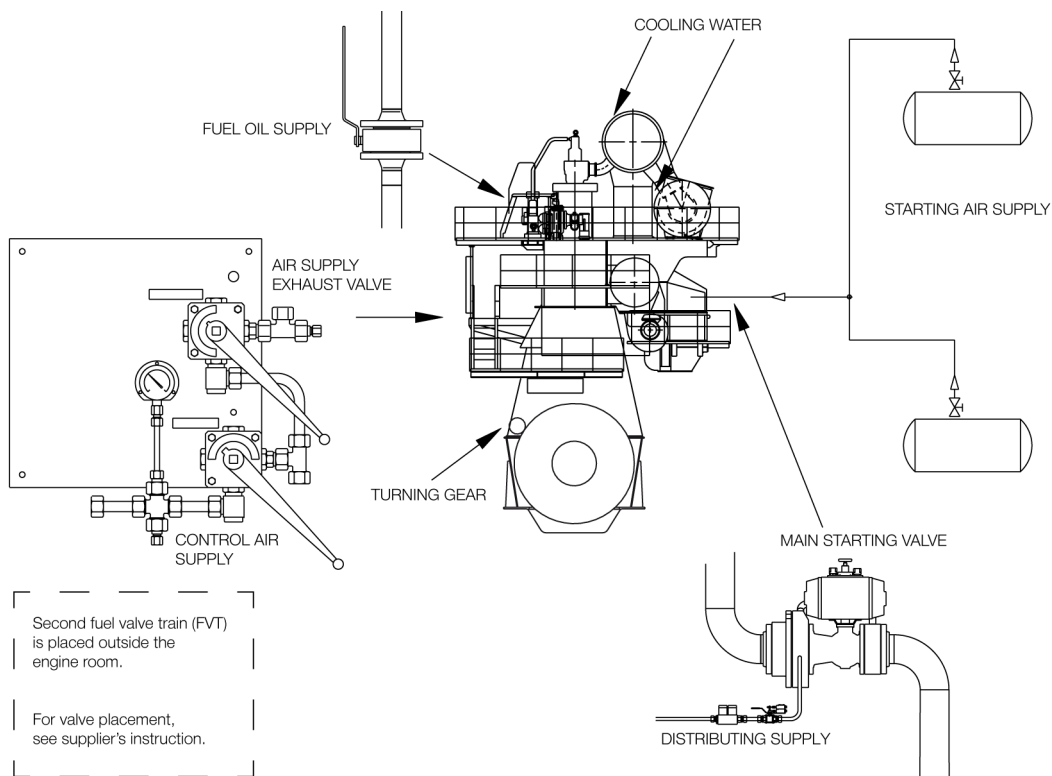

























The drawing gives the approximate location of the valves concerned



0545-0100-0010C02

### Data Sheet Signs

Data sheets may include warning signs for special dangers that could arise in connection with the maintenance procedures.

Warning signs		Mandatory action signs	
General warning sign		General mandatory action sign	
Explosive material		Wear ear protection	
Drop (fall)		Wear eye protection	
Slippery surface		Wear safety footwear	
Electricity		Wear protective gloves	
Overhead load		Wear face shield	
Hot surface		Wear head protection	
Crushing		Wear mask	
Overhead obstacle		Wear respiratory protection	
Flammable		Wear safety harness	
Crushing of hands		Disconnect before carrying out maintenance	
Pressurised cylinder		Wear antistatic footwear	



Warning signs		Mandatory action signs	
Pressurised device		Use gas detector	
Falling objects			

## General

*Correct operation and maintenance, which is the aim of this book, are crucial points for obtaining optimum safety in the engine room. The general measures mentioned here should therefore be routine practice for the entire engine crew.*

### WARNING

#### Maintenance

- Read and follow all instructions given in work cards.
- Only use original spare parts.
- Only use appropriate tools.
- Always inspect the engine when maintenance work is completed.

## Engine Room Staff

Operation and maintenance of MAN B&W engines is to be carried out exclusively by qualified professional personnel.



Minimum personal safety equipment requirements:

1. Safety shoes
2. Hearing protection, *see caution.*
3. Boiler suit or other similar protective wear

### CAUTION

#### Running engine

In case of abnormal condition during engine running, loud noise peak can occur.



Both earplugs and earmuffs must be used, in combination.

## Special Dangers



A number of situations may lead to risk of serious injury to the body. The following recommendations must always be observed:

- Keep clear of the space below a crane with load.
- Before opening of cocks, always observe which way liquids, gases or flames will move, and keep clear.
- Dismantling of parts may cause the release of springs.
- Removal of plugs may cause the release of pressurized fluids or gasses.
- Do not stand near turbochargers in case of any abnormal running.
- Do not stand near crankcase doors or relief valves – nor in corridors near doors to the engine room – if an alarm sets off for oil mist, high lube oil temperature, no piston cooling oil flow, or scavenge box fire.  
*See description 6645-0290 and 6645-0300.*

## Turning Gear

Before engaging the turning gear, ensure that the starting air supply is shut off, the main starting and slow turning valves are blocked, and that the indicator cocks are open.

When the turning gear is engaged, check that the indicator lamp “Turning gear in” has switched on.

The turning gear remote control is a critical device and should always be kept in optimal working condition. Any fault in the device or cable must be rectified before use.

*When operating the turning gear it is important to note the following:*

The turning gear must be operated by the remote control and only by the person working on the engine.

Warnings must be given before each turning. Operation of the turning gear from the switchboard must not take place while maintenance work is in progress inside the engine.

Block the switch or place a “Do not touch” sign.

## Entering the Crankcase, Cylinder Liner or Scavenge Air Receiver

### WARNING

Always ensure that the turning gear is engaged and the brake is active, to prevent external forces or unbalance of the crankshaft from turning the crankshaft.

Check that the starting air supply to the engine and the starting air distributor is shut off and that the main starting valve is locked.

Before entering the scavenge air receiver, shut off and block the auxiliary blower main starting panel.

In case of oil mist alarm, precautions must be taken before opening the doors to the crankcase (*see description 6645-0300*). Before entering, ventilate the crankcase for about 30 minutes after stopping the engine.

Work inside the crankcase requires the use of safety harness and fall arrester equipment.

Work inside the crankcase is as minimum a two-man job, and good communication must be maintained at all times.

The turning gear must always be operated exclusively by the person(s) who enters the crankcase, cylinder liner or scavenge air receiver.

## Cleanliness

The engine and engine room should always be kept clean and tidy.

Oily rags must never be left around the engine room spaces as they are highly flammable and slippery.

Remove any oil spill immediately.

If there is a risk of grit or sand blowing into the engine room, stop the ventilation and close the ventilating ducts, skylights and engine room doors.

Welding or other work that causes spreading of grit and/or swarf must not be carried out near the engine unless it is closed or protected and the turbocharger air intake filters are covered.

The exterior of the engine should be kept clean, and the paintwork maintained, so that leakages can be easily detected.

## Fire



Keep the areas around the relief valves free of oil, grease, etc. to prevent the risk of fire caused by the emitted hot air/gas if the relief valves open.

Do not weld or use naked lights in the engine room until it has been ascertained that no explosive gases, vapour or liquids are present.

If the crankcase is opened before the engine has cooled down, welding and the use of naked flames will result in the risk of explosions and fire. The same applies to inspection of oil tanks and of the spaces below the floor.

Attention is furthermore drawn to the danger of fire when using paint and solvents with a low flash point. Porous insulating material, soaked with oil from leakages, is flammable and should be renewed.

*See also description 6645-0290, -0300 and 'Sealing Materials' in this description.*

## Order/Tidiness

Hand tools should be securely fastened and placed on easily accessible tool panels. Special tools should be securely fastened close to the area of use in the engine room.

Do not store engine parts on engine galleries while the engine is running.

Do not leave major objects unfastened, and keep floor and passages clear at all times.

## Spares

Large spare parts should, as far as possible, be placed near the area of use, well secured and accessible by crane.

All spares should be protected against corrosion and mechanical damage. The stock should be checked at intervals and replenished in good time.

## Lighting

Ample working light should be permanently installed at appropriate places in the engine room spaces, and portable working light should be obtainable everywhere. 24v safety lamps must be available for use inside the engine.

### Harmful Materials

Always follow the manufacturer's specific instructions, i.e. the material safety data sheet (MSDS).

Use protective gloves, goggles, breathing mask and any other recommended protective gear stated in the material safety data sheet.

Read the material safety data sheet regarding first aid measures in the event of skin contact.

When handling harmful materials it is important to ensure proper ventilation and shielding if needed.

In the event of leaks or spillage, spread binding agents immediately. Dispose of the binding agents according to the material safety data sheet.

### Guidelines for all lifting tools

Prior to any use lifting tools must be visual inspected for cracks, corrosion, excessive wear, loose fasteners, deformations and damages.

Unidentified or damaged tools and tools not clearly marked with Safe Working Load (SWL) or Work Load Limit (WLL) must not be used. Plan the lift and determine weight of the load and center of gravity. Use designated lifting points if any and determine which lifting tool and attachment is to be used.

Plan the movement and landing of the load and safe disconnecting of lifting tools.

Beware of the sling angles:

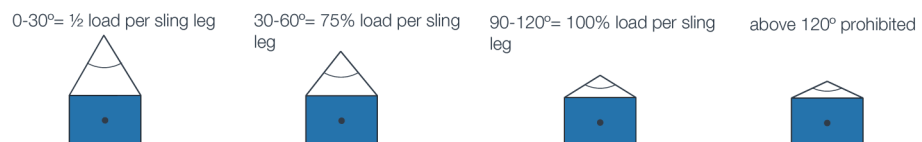





Tie down the load to avoid sliding and danger of falling objects and cover sharp edges on the load to avoid cutting wires, ropes and slings. Plan lifting of engine components through all steps of the lifting procedure.



**Never work or stay under a suspended load !**

**Synthetic web slings**

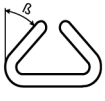
Be aware of max. load in accordance to table.

Designation	WLL	Color code	Straight Pull	Tied Pull	Parallel Pull	0°- 45°	45°- 60°
							
	t		kg	kg	kg	kg	kg
002	2	Green	2000	1600	4000	2800	2000
003	3	Yellow	3000	2400	6000	4200	3000
004	4	Grey	4000	3200	8000	5600	4000
006	6	Brown	6000	4800	12000	8400	6000
008	8	Blue	8000	6400	16000	11200	8000
010	10	Orange	10000	8000	20000	14000	10000

**Shackles**

Screwpins to be tightened to full contact – use hand tools. Bolt and nut type to be secured with cutter pin.

**Eye screw / Eye nut**

Tighten to full contact without any gap - use hand tools. Be aware of loading direction. **Lateral loading is prohibited in all cases !**

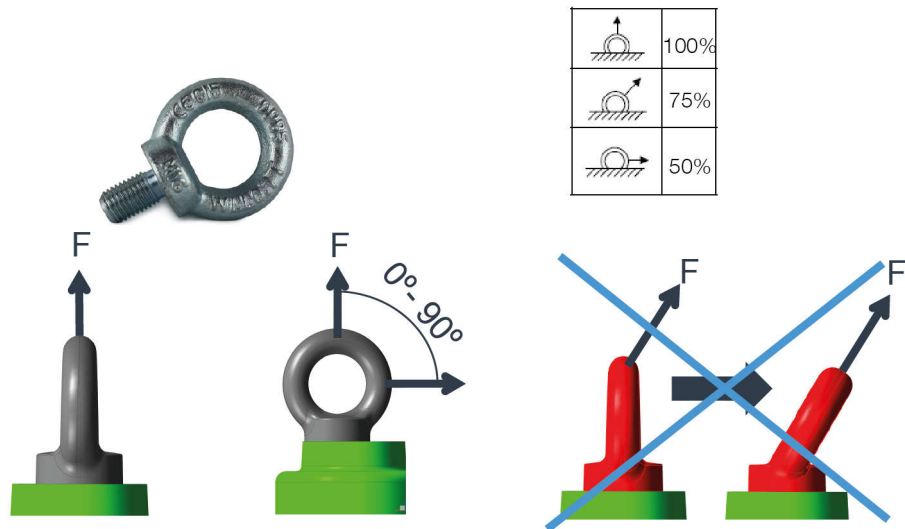

**Hooks**

Only hooks with safety latches are allowed for lifting.

**Chain tackles**

Be aware of lifting angle.

**Working Air**

Use of working air requires safety goggles and gloves.

Avoid blowing pressurised air directly at any part of the body, especially exposed skin, eyes and ears.

**Sealing Materials**

Use gloves made of neoprene or PVC when removing O-rings and other rubber/plastic-based sealing materials which have been subjected to abnormally high temperatures.

**Hot Surfaces**

Beware of hot surfaces and always use gloves.

**Splash guard**

It is required that fuel oil and lubrication oil lines and flanged connections must be screened or otherwise suitably protected to avoid oil onto hot surfaces, air intakes, electrical installations or other sources of ignition.

Splash guard removed in connection with maintenance or repair work must be reinstalled again when the work has been carried out.

**Alarms**

It is important that all alarms lead to prompt investigation and remedy of the error. No alarm is insignificant. The most serious alarms are equipped with slow-down and/or shut-down functions. It is therefore important that all engine operation personnel are well-trained in the use and importance of the alarm system.



## Fuel Gas Leakage Detection and Tightness Test



- It is **not** allowed to detect for fuel gas leakages by unscrewing the detection plugs while the system is pressurised with fuel gas.
- Detection is **only** allowed after purging with nitrogen several times and subsequently using an oxygen sensor while the system is pressurised with nitrogen.
- All personnel not relevant to the tightness test is to be evacuated from the test area.
- If the engine is stopped the leakage detection should be performed **with open indicator cocks and disengaged turning gear** in order to avoid unintentional engine turning.  
*See description 4245-0050.*

## Fuel Gas Related Maintenance Work

Pressure test the system after any kind of maintenance on parts related to the fuel gas system.

*See description 4245-0050 - 'Pipe verification test'.*

## Subsuppliers and External Equipment

Check the special instructions concerning subsupplier delivery and external equipment for specific warnings!

## Safety Notes



**DANGER**

This warning is used when an operation, procedure, or use may cause personal injury or loss of life.



**WARNING**

This warning is used when an operation, procedure, or use may cause a latently dangerous state of personal injury or loss of life.



**CAUTION**

This warning is used when an operation, procedure, or use may cause damage to or destruction of equipment and a injury.



**NOTICE**

This warning is used when an operation, procedure, or use may cause damage to or destruction of equipment.

## Safety Precautions at Maintenance

Before carrying out maintenance work, stop and block the engine according to the safety precautions given on the specific work card.

Other safety precautions than listed below may apply.

<input type="checkbox"/>	Stop the Engine
<input type="checkbox"/>	Shut off fuel gas supply to the engine (close valve 830 on FGVT)
<input type="checkbox"/>	Shut off control air supply to fuel gas valve train (FGVT)
<input type="checkbox"/>	Shut off hydraulic oil supply to control block (close valve 870 on HCU)
<input type="checkbox"/>	Drain off hydraulic oil from the control block (open valve 871 on HCU)
<input type="checkbox"/>	Shut down sealing oil unit
<input type="checkbox"/>	Shut off starting air supply - At starting air receiver
<input type="checkbox"/>	Block the main starting valve
<input type="checkbox"/>	Shut off starting air distributor/distributing system supply
<input type="checkbox"/>	Shut off control air supply
<input type="checkbox"/>	Shut off air supply to exhaust valve - Only with stopped lub. oil pumps
<input type="checkbox"/>	Engage turning gear
<input type="checkbox"/>	Shut off cooling water
<input type="checkbox"/>	Shut off fuel oil
<input type="checkbox"/>	Stop lubricating oil supply
<input type="checkbox"/>	Shut down hydraulic power supply
<input type="checkbox"/>	Shut off and block the auxiliary blowers

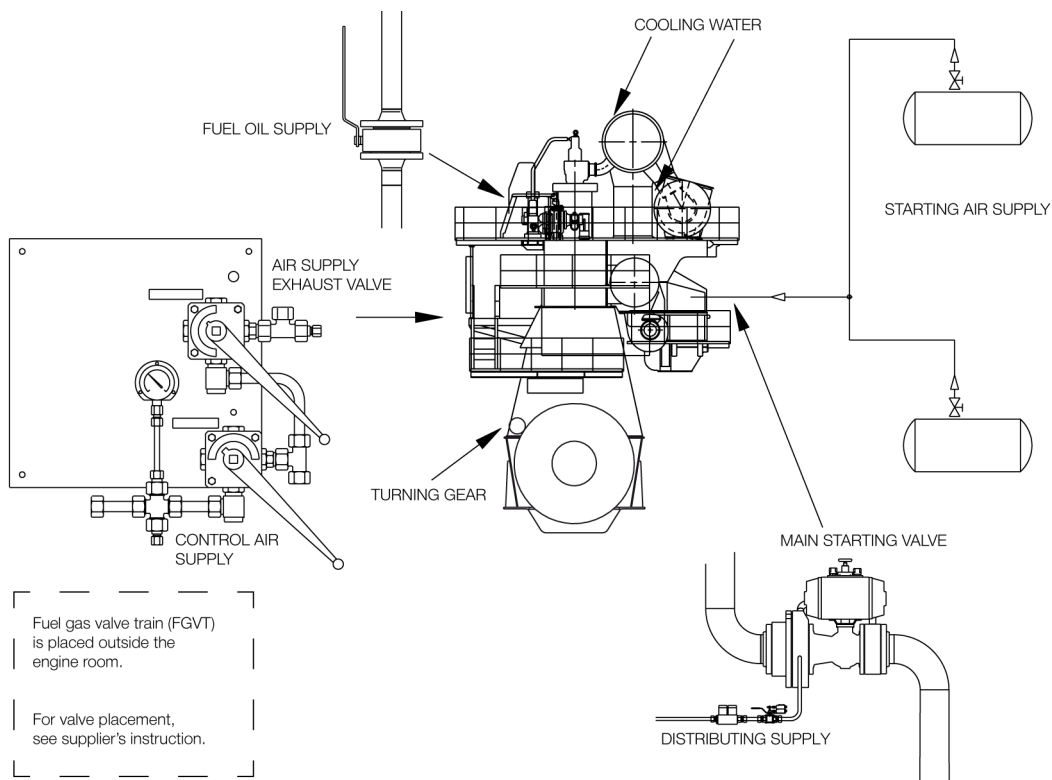



























The drawing gives the approximate location of the valves concerned

0545-0100-0009C02

### Data Sheet Signs

Data sheets may include warning signs for special dangers that could arise in connection with the maintenance procedures.

Warning signs		Mandatory action signs	
General warning sign		General mandatory action sign	
Explosive material		Wear ear protection	
Drop (fall)		Wear eye protection	
Slippery surface		Wear safety footwear	
Electricity		Wear protective gloves	
Overhead load		Wear face shield	
Hot surface		Wear head protection	
Crushing		Wear mask	
Overhead obstacle		Wear respiratory protection	
Flammable		Wear safety harness	
Crushing of hands		Disconnect before carrying out maintenance	
Pressurised cylinder		Wear antistatic footwear	

Warning signs		Mandatory action signs	
Pressurised device		Use gas detector	
Falling objects			

General

*Correct operation and maintenance, which is the aim of this book, are crucial points for obtaining optimum safety in the engine room. The general measures mentioned here should therefore be routine practice for the entire engine crew.*



**Maintenance**

- Read and follow all instructions given in work cards.
- Only use original spare parts.
- Only use appropriate tools.
- Always inspect the engine when maintenance work is completed.

**Engine Room Staff**

Operation and maintenance of MAN B&W engines is to be carried out exclusively by qualified professional personnel.



Minimum personal safety equipment requirements:

1. Safety shoes
2. Hearing protection, *see caution.*
3. Boiler suit or other similar protective wear



**Running engine**

In case of abnormal condition during engine running, loud noise peak can occur.



Both earplugs and earmuffs must be used, in combination.

## Special Dangers



A number of situations may lead to risk of serious injury to the body. The following recommendations must always be observed:

- Keep clear of the space below a crane with load.
- Before opening of cocks, always observe which way liquids, gases or flames will move, and keep clear.
- Dismantling of parts may cause the release of springs.
- Removal of plugs may cause the release of pressurized fluids or gasses.
- Do not stand near turbochargers in case of any abnormal running.
- Do not stand near crankcase doors or relief valves – nor in corridors near doors to the engine room – if an alarm sets off for oil mist, high lube oil temperature, no piston cooling oil flow, or scavenge box fire.  
*See description 6645-0290 and 6645-0300.*

## Turning Gear

Before engaging the turning gear, ensure that the starting air supply is shut off, the main starting and slow turning valves are blocked, and that the indicator cocks are open.

When the turning gear is engaged, check that the indicator lamp “Turning gear in” has switched on.

The turning gear remote control is a critical device and should always be kept in optimal working condition. Any fault in the device or cable must be rectified before use.

*When operating the turning gear it is important to note the following:*

The turning gear must be operated by the remote control and only by the person working on the engine.

Warnings must be given before each turning. Operation of the turning gear from the switchboard must not take place while maintenance work is in progress inside the engine.

Block the switch or place a “Do not touch” sign.

## Entering the Crankcase, Cylinder Liner or Scavenge Air Receiver



Always ensure that the turning gear is engaged and the brake is active, to prevent external forces or unbalance of the crankshaft from turning the crankshaft.

Check that the starting air supply to the engine and the starting air distributor is shut off and that the main starting valve is locked.

Before entering the scavenge air receiver, shut off and block the auxiliary blower main starting panel.

In case of oil mist alarm, precautions must be taken before opening the doors to the crankcase (*see description 6645-0300*). Before entering, ventilate the crankcase for about 30 minutes after stopping the engine.

Work inside the crankcase requires the use of safety harness and fall arrester equipment.

Work inside the crankcase is as minimum a two-man job, and good communication must be maintained at all times.

The turning gear must always be operated exclusively by the person(s) who enters the crankcase, cylinder liner or scavenge air receiver.

## Cleanliness

The engine and engine room should always be kept clean and tidy.

Oily rags must never be left around the engine room spaces as they are highly flammable and slippery.

Remove any oil spill immediately.

If there is a risk of grit or sand blowing into the engine room, stop the ventilation and close the ventilating ducts, skylights and engine room doors.

Welding or other work that causes spreading of grit and/or swarf must not be carried out near the engine unless it is closed or protected and the turbocharger air intake filters are covered.

The exterior of the engine should be kept clean, and the paintwork maintained, so that leakages can be easily detected.



## Fire



Keep the areas around the relief valves free of oil, grease, etc. to prevent the risk of fire caused by the emitted hot air/gas if the relief valves open.

Do not weld or use naked lights in the engine room until it has been ascertained that no explosive gases, vapour or liquids are present.

If the crankcase is opened before the engine has cooled down, welding and the use of naked flames will result in the risk of explosions and fire. The same applies to inspection of oil tanks and of the spaces below the floor.

Attention is furthermore drawn to the danger of fire when using paint and solvents with a low flash point. Porous insulating material, soaked with oil from leakages, is flammable and should be renewed.

*See also description 6645-0290, -0300 and 'Sealing Materials' in this description.*

## Order/Tidiness

Hand tools should be securely fastened and placed on easily accessible tool panels. Special tools should be securely fastened close to the area of use in the engine room.

Do not store engine parts on engine galleries while the engine is running.

Do not leave major objects unfastened, and keep floor and passages clear at all times.

## Spares

Large spare parts should, as far as possible, be placed near the area of use, well secured and accessible by crane.

All spares should be protected against corrosion and mechanical damage. The stock should be checked at intervals and replenished in good time.

## Lighting

Ample working light should be permanently installed at appropriate places in the engine room spaces, and portable working light should be obtainable everywhere. 24v safety lamps must be available for use inside the engine.

### Harmful Materials

Always follow the manufacturer's specific instructions, i.e. the material safety data sheet (MSDS).

Use protective gloves, goggles, breathing mask and any other recommended protective gear stated in the material safety data sheet.

Read the material safety data sheet regarding first aid measures in the event of skin contact.

When handling harmful materials it is important to ensure proper ventilation and shielding if needed.

In the event of leaks or spillage, spread binding agents immediately. Dispose of the binding agents according to the material safety data sheet.

### Guidelines for all lifting tools

Prior to any use lifting tools must be visual inspected for cracks, corrosion, excessive wear, loose fasteners, deformations and damages.

Unidentified or damaged tools and tools not clearly marked with Safe Working Load (SWL) or Work Load Limit (WLL) must not be used. Plan the lift and determine weight of the load and center of gravity. Use designated lifting points if any and determine which lifting tool and attachment is to be used.

Plan the movement and landing of the load and safe disconnecting of lifting tools.

Beware of the sling angles:

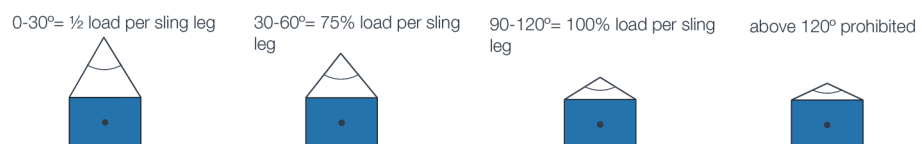

Tie down the load to avoid sliding and danger of falling objects and cover sharp edges on the load to avoid cutting wires, ropes and slings. Plan lifting of engine components through all steps of the lifting procedure.



**Never work or stay under a suspended load !**

**Synthetic web slings**

Be aware of max. load in accordance to table.

Designation	WLL	Color code	Straight Pull	Tied Pull	Parallel Pull	0°- 45°	45°- 60°
	t		kg	kg	kg	kg	kg
002	2	Green	2000	1600	4000	2800	2000
003	3	Yellow	3000	2400	6000	4200	3000
004	4	Grey	4000	3200	8000	5600	4000
006	6	Brown	6000	4800	12000	8400	6000
008	8	Blue	8000	6400	16000	11200	8000
010	10	Orange	10000	8000	20000	14000	10000

**Shackles**

Screwpins to be tightened to full contact – use hand tools. Bolt and nut type to be secured with cutter pin.

**Eye screw / Eye nut**

Tighten to full contact without any gap - use hand tools. Be aware of loading direction. **Lateral loading is prohibited in all cases !**

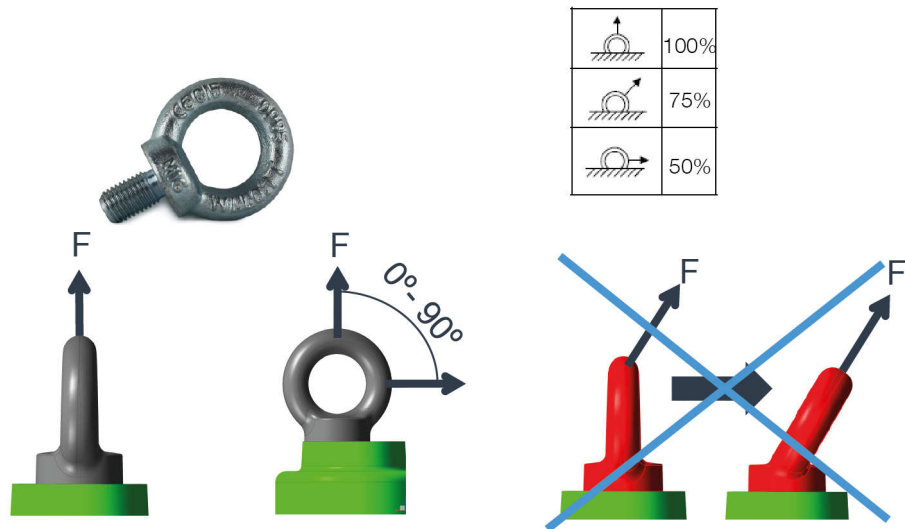

**Hooks**

Only hooks with safety latches are allowed for lifting.

**Chain tackles**

Be aware of lifting angle.

**Working Air**

Use of working air requires safety goggles and gloves.

Avoid blowing pressurised air directly at any part of the body, especially exposed skin, eyes and ears.

**Sealing Materials**

Use gloves made of neoprene or PVC when removing O-rings and other rubber/plastic-based sealing materials which have been subjected to abnormally high temperatures.

**Hot Surfaces**

Beware of hot surfaces and always use gloves.

**Splash guard**

It is required that fuel oil and lubrication oil lines and flanged connections must be screened or otherwise suitably protected to avoid oil onto hot surfaces, air intakes, electrical installations or other sources of ignition.

Splash guard removed in connection with maintenance or repair work must be reinstalled again when the work has been carried out.

**Alarms**

It is important that all alarms lead to prompt investigation and remedy of the error. No alarm is insignificant. The most serious alarms are equipped with slow-down and/or shut-down functions. It is therefore important that all engine operation personnel are well-trained in the use and importance of the alarm system.

## Subsuppliers and External Equipment

Check the special instructions concerning subsupplier delivery and external equipment for specific warnings!

## Safety Notes



**DANGER**

This warning is used when an operation, procedure, or use may cause personal injury or loss of life.



**WARNING**

This warning is used when an operation, procedure, or use may cause a latently dangerous state of personal injury or loss of life.



**CAUTION**

This warning is used when an operation, procedure, or use may cause damage to or destruction of equipment and a injury.



**NOTICE**

This warning is used when an operation, procedure, or use may cause damage to or destruction of equipment.

### Safety Precautions at Maintenance

Before carrying out maintenance work, stop and block the engine according to the safety precautions given on the specific work card.

Other safety precautions than listed below may apply.

<input type="radio"/>	Stop the Engine
<input type="radio"/>	Shut off starting air supply - At starting air receiver
<input type="radio"/>	Block the main starting valve
<input type="radio"/>	Shut off starting air distributor/distributing system supply
<input type="radio"/>	Shut off safety air supply - Not ME Engines
<input type="radio"/>	Shut off control air supply
<input type="radio"/>	Shut off air supply to exhaust valve - Only with stopped lub. oil pumps
<input type="radio"/>	Engage turning gear
<input type="radio"/>	Shut off cooling water
<input type="radio"/>	Shut off fuel oil
<input type="radio"/>	Stop lubricating oil supply
<input type="radio"/>	Shut down hydraulic power supply
<input type="radio"/>	Shut off and block the auxiliary blowers

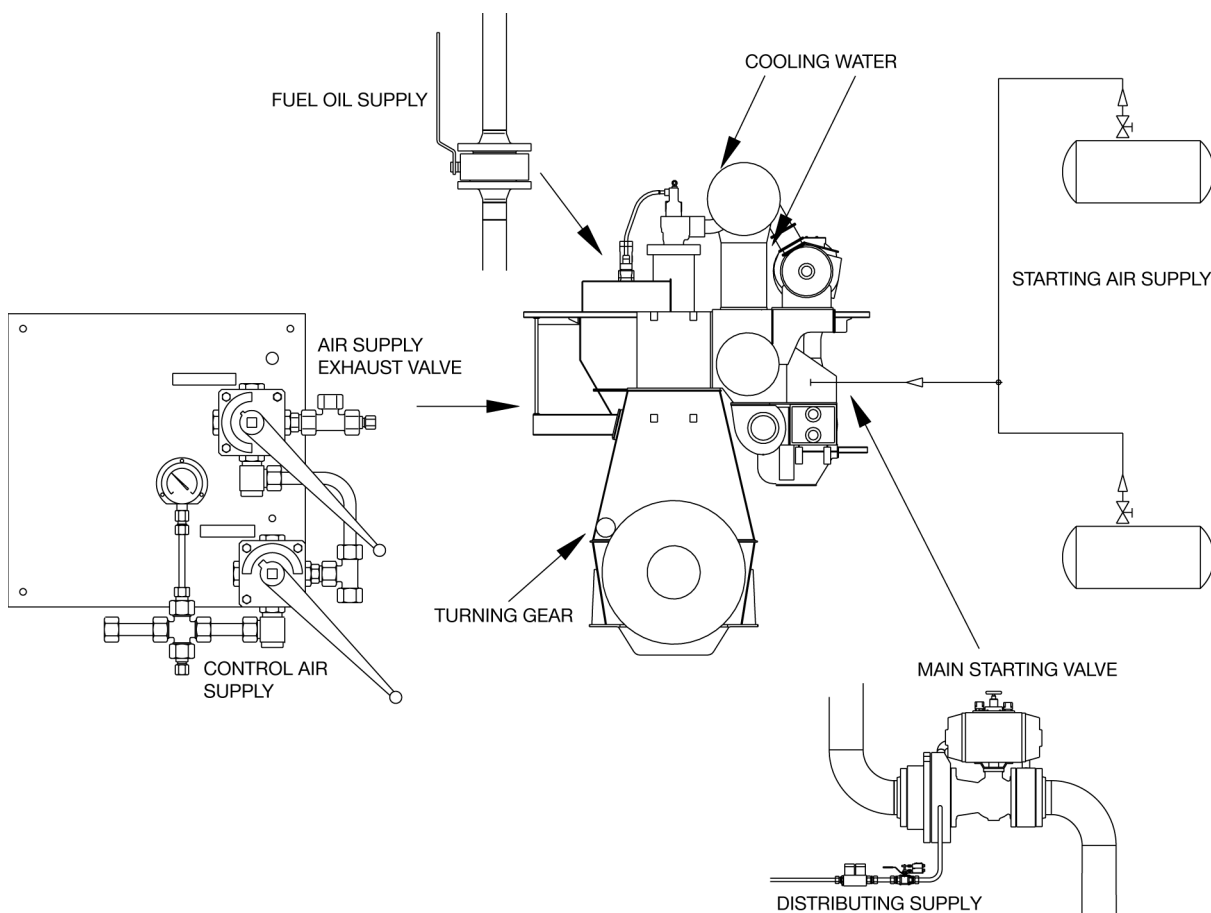

























The drawing gives the approximate location of the valves concerned.



0545-0100-0008C02

2017-09-21 - en

## Data Sheet Signs

Data sheets may include warning signs for special dangers that could arise in connection with the maintenance procedures.

Warning signs		Mandatory action signs	
General warning sign		General mandatory action sign	
Explosive material		Wear ear protection	
Drop (fall)		Wear eye protection	
Slippery surface		Wear safety footwear	
Electricity		Wear protective gloves	
Overhead load		Wear face shield	
Hot surface		Wear head protection	
Crushing		Wear mask	
Overhead obstacle		Wear respiratory protection	
Flammable		Wear safety harness	
Crushing of hands		Disconnect before carrying out maintenance	
Pressurised cylinder		Wear antistatic footwear	

Warning signs		Mandatory action signs	
Pressurised device		Use gas detector	
Falling objects	