

Action code: **WHEN CONVENIENT**

### CPR Ring Pack Configuration

New piston ring standard for large bore engines

SL2016-611/JAP  
January 2016

#### Concerns

Owners and operators of MAN B&W two-stroke marine diesel engines. Type: G95ME-C, S90, G80, S80 and G70 Mk 9/10.

#### Summary

New CPR ring pack configuration standard for large bore engines of the above mentioned type.

.....

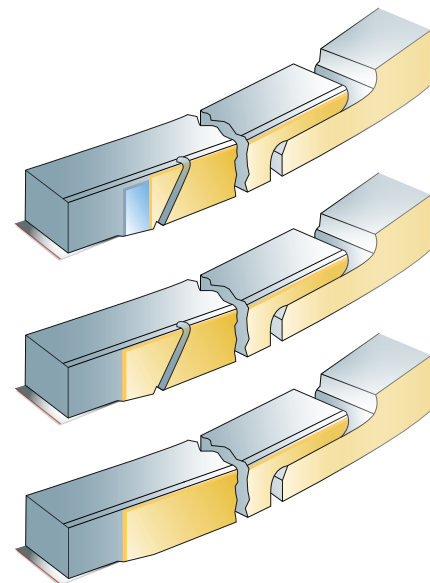

Dear Sirs

In an effort to continuously improve the cylinder condition we now update the piston ring pack configuration and piston crown design for our latest high-rated large bore low speed engines type: S80, G80, S90 and G95ME-C Mk 9/10. The change of standard is based on positive experience from the G70ME-C9 and S80ME-C9 engines.

New engines will be fitted with CPR ring packs featuring high-type rings with cermet-coating on the top ring and alu-coating as the running-in coating on all three rings. All three rings will be produced with chromium on the lower face for improved piston ring groove lifetime and will also have gas tight (GT) double S-locks. The two upper rings will have controlled leakage (CL) grooves. Ring No. 3 will be gas tight (no CL-grooves), while ring No. 2 will be more restrictive than the top ring.

For some engines already in service, the ring pack to be ordered by the shipowner, and supplied as a spare part, is identical to the above described layout, but will include low-type rings for grooves Nos. 2 and 3.

**To receive the correct type of piston ring package it is important to state the type of crown (i.e., 1 high & 2 low ring grooves or 3 high ring grooves) when requesting new rings.**

Yours faithfully

**Mikael C Jensen**  
Vice President, Engineering

**Stig B Jakobsen**  
Senior Manager, Operation

**Head office (& postal address)**  
**MAN Diesel & Turbo**  
Tegholmegade 41  
2450 Copenhagen SV  
Denmark  
Phone: +45 33 85 11 00  
Fax: +45 33 85 10 30  
info-cph@mandieselturbo.com  
www.mandieselturbo.com

**PrimeServ**  
Tegholmegade 41  
2450 Copenhagen SV  
Denmark  
Phone: +45 33 85 11 00  
Fax: +45 33 85 10 49  
PrimeServ-cph@mandieselturbo.com

**Production**  
Tegholmegade 35  
2450 Copenhagen SV  
Denmark  
Phone: +45 33 85 11 00  
Fax: +45 33 85 10 17  
manufacturing-dk@mandieselturbo.com

**Forwarding & Receiving**  
Tegholmegade 35  
2450 Copenhagen SV  
Denmark  
Phone: +45 33 85 11 00  
Fax: +45 33 85 10 16  
shipping-cph@mandieselturbo.com

**MAN Diesel & Turbo**  
Branch of MAN Diesel & Turbo SE,  
Germany  
CVR No.: 31611792  
Head office: Tegholmegade 41  
2450 Copenhagen SV, Denmark  
German Reg.No.: HRB 22056  
Amtsgericht Augsburg

**Piston crowns**

**1.** New engines will be specified with piston crowns with three high piston ring grooves, see Fig. 1.

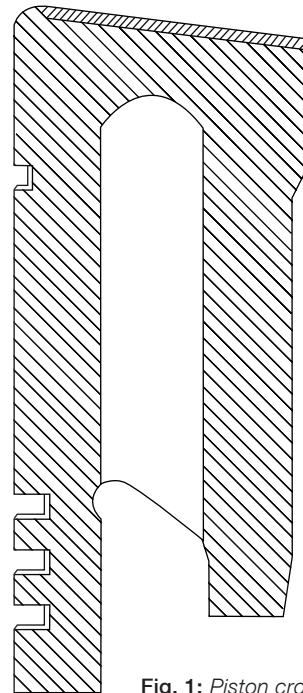
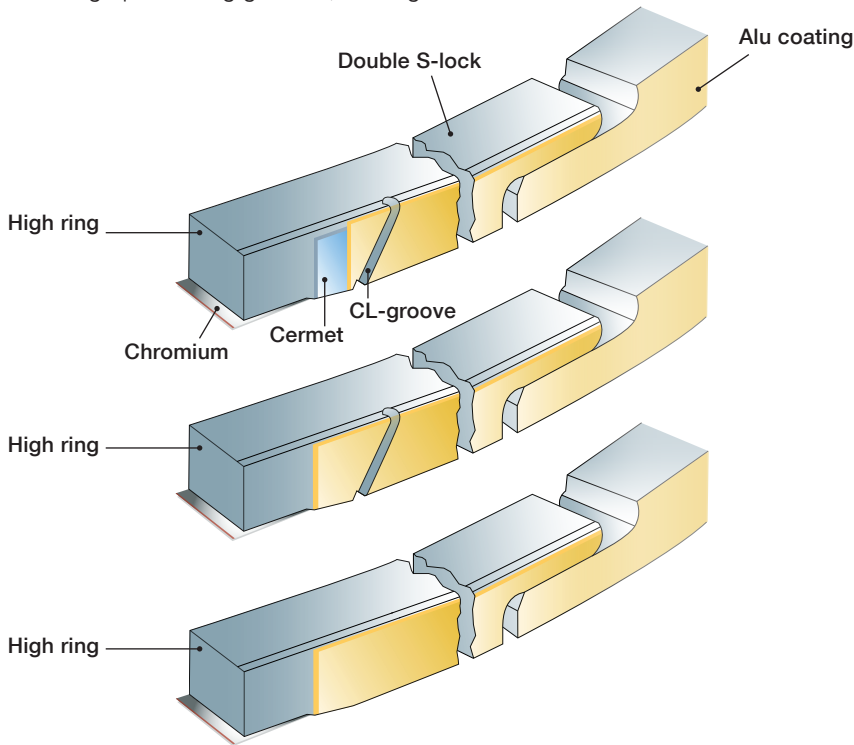

**Fig. 1:** Piston crown with three high piston ring grooves and the corresponding CPR ring pack (i.e., 3 high rings).

**2.** Engines already in service with four groove piston crowns will continue as four ring groove piston crowns with the CPR piston ring pack shown in figure 2 (i.e., 1 high & 2 low rings) leaving the lowest piston ring groove empty.

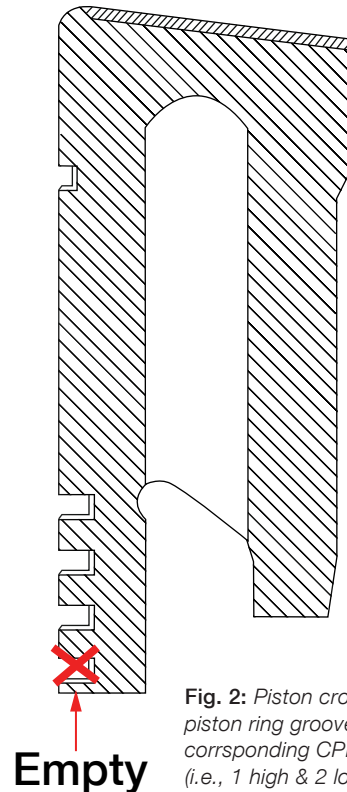
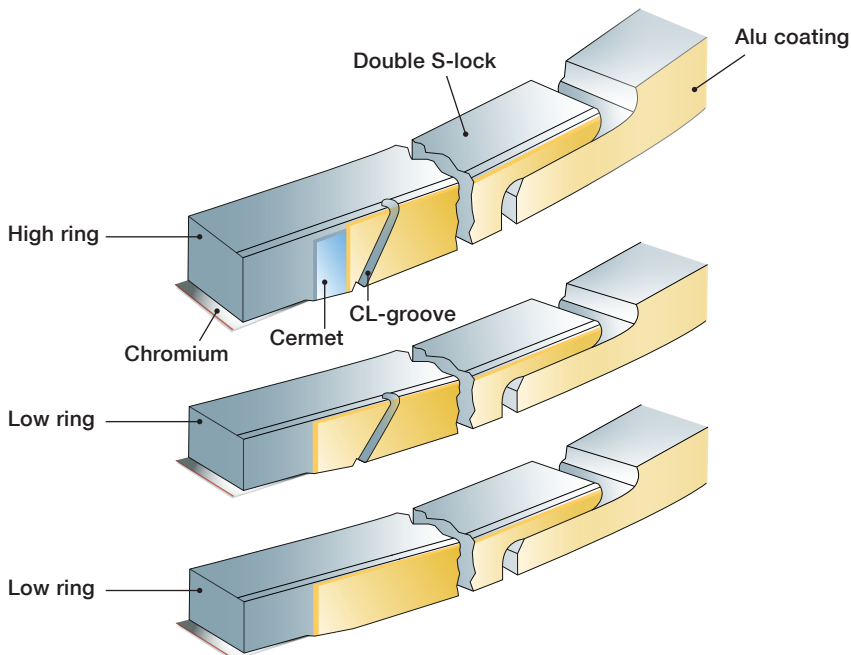

**Fig. 2:** Piston crown with four piston ring grooves and the corresponding CPR ring pack (i.e., 1 high & 2 low rings).

