

Action code: AT FIRST OPPORTUNITY

**Testing of Overspeed on L23/30H GenSets**

SL2015-600/JEC  
April 2015

**Concerns**

Owners and operators of  
MAN four-stroke diesel engines.  
Type: L23/30H GenSets

Dear Sirs

Based on the observation of a recent incident involving overspeed, we need to emphasize that the overspeed system must be tested according to the classification society rules and safety precautions informed in the Instruction Manual.

The Instruction Manual specifies that the functionality of the safety control system, including overspeed prevention, must be tested at least every third month, as described in "Planned Maintenance Programme (500.25)". By regular testing of the overspeed prevention functionality, the risk of suffering unexpected consequential damage to engine and/or personnel is minimised.

If you find any irregularities in the overspeed or safety control system, please contact PrimeServ for rectification.

Yours faithfully

.....  
Enclosure:

Work card 509-01.05 (01),  
Functional test and adjustment of over-speed trip



**Mikael C. Jensen**  
Vice President  
Engineering



**Jens Christensen**  
Manager Maturing & Field testing  
Four-stroke

Work Card Page 1 (3)	<b>Functional test and adjustment of overspeed trip</b>	<b>509-01.05</b> <b>Edition 01</b>
-------------------------	---	---------------------------------------

**L23/30H, L23/30S**

<p><b>Safety precautions</b></p> <ul style="list-style-type: none"> <li><input type="checkbox"/> Engine stopped</li> <li><input type="checkbox"/> Shut-off starting air</li> <li><input type="checkbox"/> Shut off cooling water</li> <li><input type="checkbox"/> Shut off fuel oil</li> <li><input type="checkbox"/> Shut-off cooling oil</li> <li><input type="checkbox"/> Stop lub. oil circulation</li> <li><input type="checkbox"/> Press Blocking - Reset</li> </ul> <p><b>Short Description</b></p> <p>Functional test and adjustment of overspeed trip</p> <p><b>Starting Position</b></p> <p>Functional test and adjustment of safety alarm and monitoring equipment 509-01.00</p> <p><b>Related Procedure</b></p> <p><b>Qualified Manpower</b></p> <p>Duration in h : 1 Number : 1</p> <p><b>Data</b></p> <p>Data for pressure and tolerance (Page 500.35) Data for tightening torque (Page 500.40) Declaration of weight (Page 500.45)</p>	<p><b>Special tools</b></p> <table style="width: 100%; border-collapse: collapse;"> <thead> <tr> <th style="text-align: left;">Plate No.</th> <th style="text-align: left;">Item No.</th> <th style="text-align: left;">Note</th> </tr> </thead> <tbody> <tr> <td>52009</td> <td>016</td> <td></td> </tr> </tbody> </table> <p><b>Hand Tools</b></p> <p><b>Replacement and wearing parts</b></p> <table style="width: 100%; border-collapse: collapse;"> <thead> <tr> <th style="text-align: left;">Plate No.</th> <th style="text-align: left;">Item No.</th> <th style="text-align: left;">Quantity</th> </tr> </thead> <tbody> <tr> <td> </td> <td> </td> <td> </td> </tr> </tbody> </table>	Plate No.	Item No.	Note	52009	016		Plate No.	Item No.	Quantity			
Plate No.	Item No.	Note											
52009	016												
Plate No.	Item No.	Quantity											

## L23/30H, L23/30S



## Health Risk!



## Health Risk!

Due to vibrations during engine operation, especially in awkward positions!

## Description

- 1) The engine is run up manually, (on governor "synchronizer") and at no load, while watching the tachometer.

On reaching the revolution number *indicated on page 500.30* or in "Test Report", the overspeed tripping device must function, thus actuating the stop cylinders. The fuel injection pump control rods are now moved to zero index, and the engine stops.

- 2) If the overspeed device trip at a revolution number different from that *stated on page 500.30* or in the "Test Report" the overspeed device must be adjusted. Adjustment of Overspeed Trip.

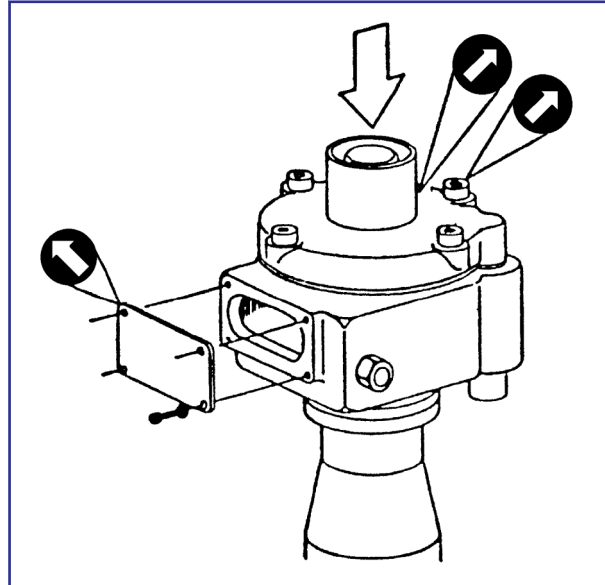

Figure 1: .

## Adjustment of overspeed trip

- 3) Remove both covers on the housing of the overspeed tripping device, *see fig. 1*.

Turn the engine until the adjusting screw is opposite the opening on the side of the housing. Now loosen the lock screw and turn the adjusting screw, using the tubular pin spanner supplied, *see fig. 2*.

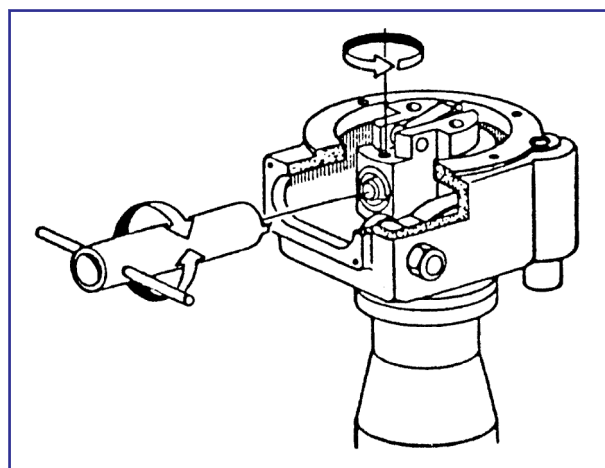

Figure 2: .

Turn the adjusting screw outwards (slacken fly-weight spring) to reduce the revolution number. Be careful not to screw the adjusting screw so far out that it may touch the release arm. Tighten the lock screw and test the overspeed device again.

### L23/30H, L23/30S

- 4) Refit the covers when the overspeed device functions at correct revolution number.
- 5) The overspeed device can be tested manually by depressing the button on top of the housing, *see fig. 1*. This will activate the flyweight and the arm for release of the air valve for the stop cylinders and the engine should thus stop. (This test must also be carried out without load).
- 6) It is recommended now and then, while the engine is at a standstill, to move the flyweight by means of the push button to ensure that the flyweight can always move with sufficient ease.