

Two-stage Cooler

MAN Asset+

The Two-stage Cooler is a new and unique design of scavenge air cooler that enables energy from the scavenge air cooling process to be used for other on-board energy-consuming processes.

How the thermal energy is used on board

Instead of releasing the thermal energy into the water, the first stage of the process makes energy available for on-board energy-consuming processes such as increasing boiler feed water temperature, gas vaporization, freshwater production, or air conditioning. It can also be used for the organic Rankine cycle system and the ballast water treatment system.

The Two-stage Cooler is one of many MAN Asset+ solutions to raise ship performance, which keep your equipment up to date, and help you comply with environmental regulations, advancing your operations further towards energy transition and decarbonization.



Lower fuel consumption

Using the energy from the scavenge air cooler results in fuel savings as less fuel is needed to generate energy.



Fits into existing cooler box

The new two-stage scavenge air cooler is designed as one single cooler element that fits into the original scavenge air cooler frame.



Better CII rating

A lower fuel consumption helps decarbonizing and improves the Carbon Intensity Indicator (CII) rating of the vessel.

Two-stage Cooler

MAN Asset+

In order to capture energy from the scavenge air, two cooling loops are used. The first-stage loop circulates water which is at a very high temperature via a heat exchanger, for allowing heat energy to be made available to other on-board processes. The second-stage water loop cools the remaining scavenge air, as required by the engine.

The Two-stage Cooler helps make your engine more ...



Efficient

Schematic design of the Two-stage Cooler

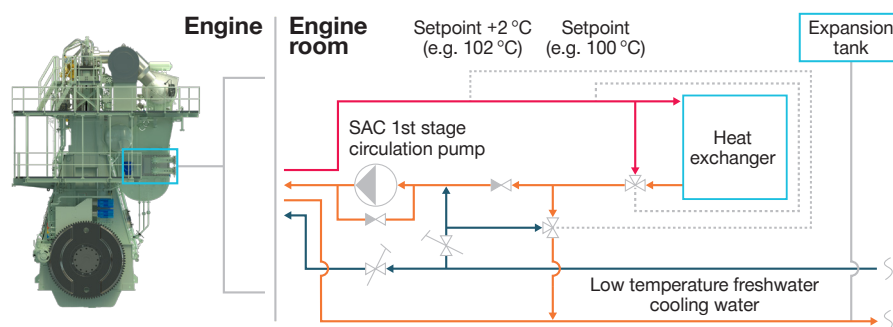

Available for new engines

The Two-stage Cooler can be added as an Asset+ solution for all MAN B&W two-stroke engines, subject to a pre-study. MAN Energy Solutions will assist in the decision-making process by supplying a pre-decision analysis that may include:

- A preliminary scavenge air cooler design for the division between the first and second stage for optimal heat utilisation based on engine type and rating.
- Water flow distribution design between first and second stage with regard to engine performance.
- Project-specific engine part-load calculations of the available heat for utilisation with unchanged engine performance.

MAN Energy Solutions

2450 Copenhagen, Denmark

P + 45 33 85 11 00

F + 45 33 85 10 49

assetplus-solutions@man-es.com

www.man-es.com