

MAN RG

Integrally geared compressors

MAN RG compressors feature a multi-stage arrangement with up to five pinions and up to ten impeller stages. Intercooling is possible after each stage, which lowers power needs, and individual process stages within one casing are also possible for more efficient operation. All shafts are equipped with maintenance-free tilting pad bearings. This enables a very

compact design, compression of a wide range of gases, and a high pressure ratio. Improved impeller design, pinion speeds, and aerodynamics guarantee the highest level of efficiency. We manufacture our own gears. The MAN RG compressor is available in different sizes with flow rates up to 600,000 m³/h.

Benefits at a glance

- Gears manufactured in-house
- Intercooling possible after each stage
- Individual process stages within one casing possible

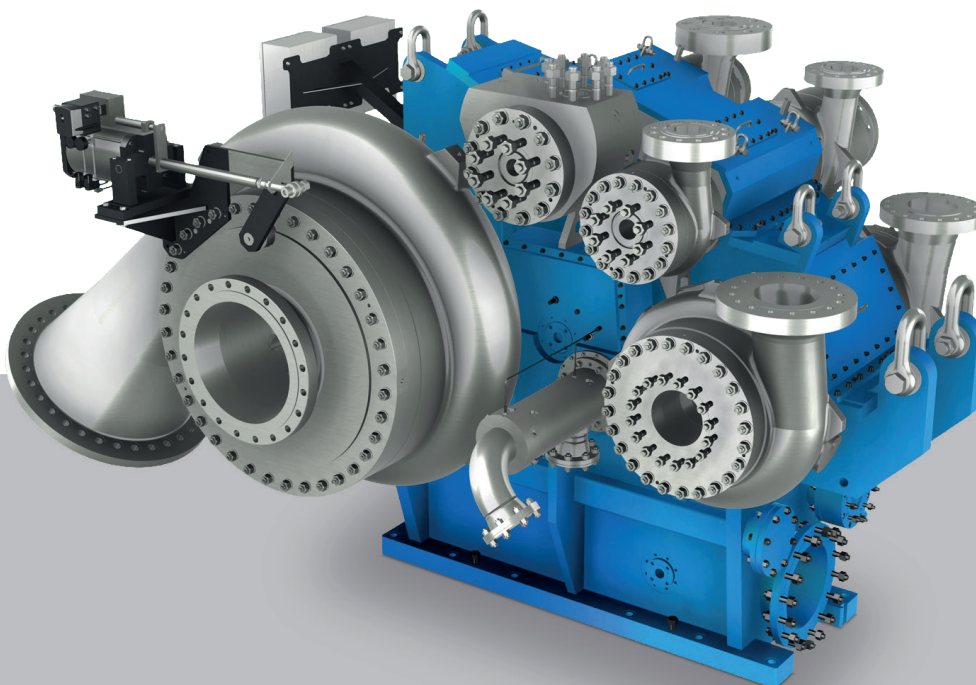

MAN RG

High efficiency multi-shaft centrifugal compressors

Dimensions¹

Type*		RG16	RG25	RG40	RG45	RG50	RG56	RG80	RG100	RG140	RG160
L	mm	2,000	2,400	4,200	4,300	4,400	4,500	6,200	7,200	10,000	12,000
H	mm	1,800	2,000	3,100	3,400	3,600	3,800	4,000	4,200	5,900	6,500
W	mm	2,000	2,300	3,000	3,200	3,300	3,500	4,000	5,000	6,700	7,500
Weight	t	3.5	15	30	40	45	50	> 60	> 80	> 100	> 140

*Dimensions related to core unit

Output

	Flow in Am ³ /h	Power in MW
RG16	1,000	1
RG25	10,000	4
RG40	25,000	15
RG45	30,000	18
RG50	40,000	20
RG56	50,000	20
RG80	100,000	20
RG100	200,000	35
RG140	350,000	50
RG160	600,000	75

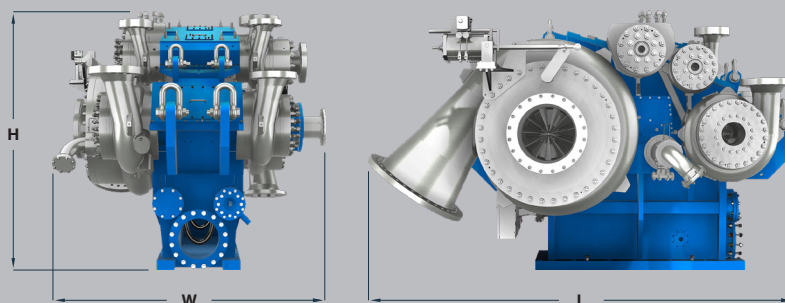

¹ Also available in the following sizes: MAN RG18, 20, 22, 28, 31, 35, 63, 71, 90, 112, 125.

Further information on these sizes and more technical information on request. Dimensions may vary depending on project requirements. Last updated June 2024

Compressor features

General data

- Driver: Electric motor, steam turbine or gas turbine
- Min. suction pressure, in compliance with API: 0.03 bara
- Discharge pressure: Max. 250 bara
- Flow rate: Max. 600,000 m³/h
- Power range: Up to 75 MW
- Efficiency: > 88 % overall efficiency possible
- Number of pinions: Max. 5
- Number of impellers: Max. 10

Modular configuration

We supply modular compressors for air, fuel gas booster and CO₂ applications as well as custom-manufactured high pressure compressors. The use of standardized preassembled components with proven track records in performance and reliability can significantly shorten delivery times. You can specify individual pinion speeds from 3,000 – 50,000 rpm, and impeller sizes from 90 to 1,800 mm. Discharge temperatures can go up to 450 °C.

Multistage design

The multistage design is fully compliant with API requirements and enables individual speed settings for each pinion. There is intercooling between each stage. Each unit can thus offer multiple services.

Applications

- Industrial gases
- Carbon capture, utilization, and storage (CCUS)
- Heat pumps
- Hydrogen (H₂)
- High-temperature compression
- Oil & gas
- Refineries
- Chemicals & petrochemicals
- Fertilizer industry
- Iron & steel, mining
- Power generation

Flexible control system

- Anti-surge system for multiple stage groups
- Performance control
- Inlet guide vanes at first or at several compressor stages
- Variable speed control and suction throttling options or combinations

MAN Energy Solutions

86224 Augsburg, Germany
P + 49 821 322-0
F + 49 821 322-3382
info@man-es.com
www.man-es.com

MAN Energy Solutions

Egellsstr. 21
13507 Berlin, Germany
P + 49 30 440402-0
F + 49 30 440402-2000