



Spare parts
and propeller
know-how

Propeller reliability package

MAN PrimeServ

Reliability spare parts
offer the safe route to
secure your operation



The best CP propeller service

MAN PrimeServ is proud to have the Propeller Maintenance Concept (PMC) continuously matured and refined for the full range of MAN Alpha CP propeller (CPP) series type VB and VBS. The maintenance concept and service recommendations for 5- and 10-year operations are aligned with the major Classification Societies in relation to the ships' dry-docking intervals.

To keep you proactively prepared, and to safeguard full continuous operation between 5-year dockings, we offer our 'reliability package' with a focus on:

- State of the supply market
- Reliability spare parts kits
- Features and benefits
- Scope of supply – maker's recommendation
- Service with passion
- Worldwide service



State of the supply market

**CPP
parts**

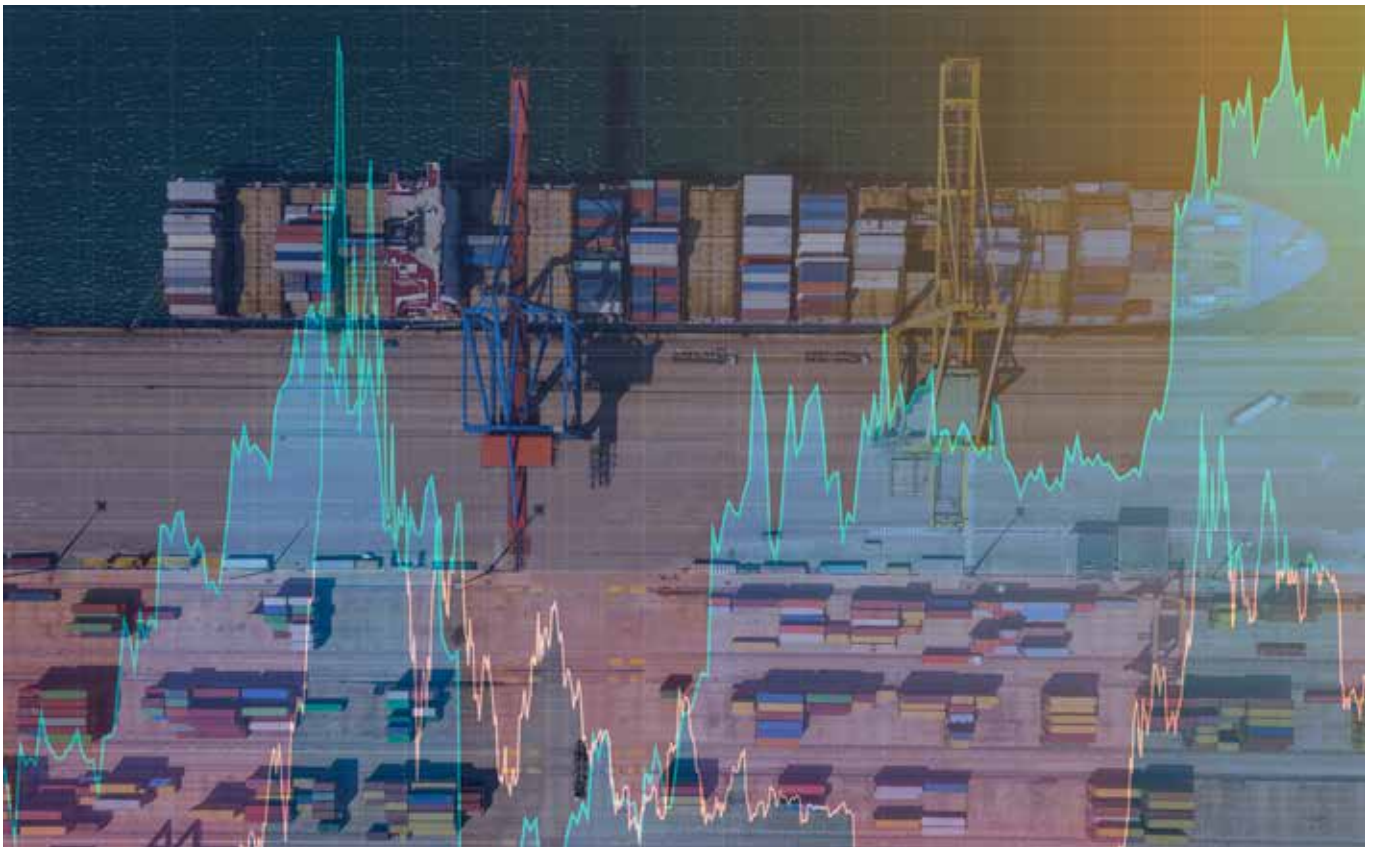



Plan ahead and stay ahead of the volatile supply situation

Reasons for concern

The global supply market has become a turbulent arena, where raw materials and finished products alike are caught in a whirlwind of volatility. Geopolitical tensions, security crises along key maritime routes, and strained suppliers have all contributed to an unstable situation. As a result, critical components and parts face unprecedented challenges.

What you need to know

Essential materials are at risk. The very foundation of propeller, control system, and automation component production hangs in the balance. Unfortunately, this volatility threatens our stock levels, potentially affecting our ability to swiftly deliver critical spare parts during urgent situations.

Our call to action

To mitigate uncertainty, we urge you to take some proactive steps:

- Maintain buffer stocks: Safeguard your operations by holding sufficient components in stock.
- Collaborate closely and engage in clear communication with us. Flexibility and safety are paramount.
- Reach out promptly to reduce risk. Let's navigate these turbulent waters together.

Contact us directly on:
primeserv-frh@man-es.com
– or via our local offices and service centers.

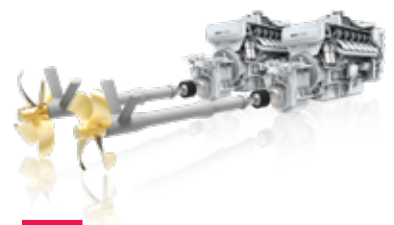

CP-propelled propulsion systems

A vast number of tailored solutions are offered today - for individually optimized applications ranging e.g., from a MAN 175D high-speed engine powered patrol boat with VB 440 propellers, up to a MAN B&W two-stroke 80-bore powered container vessel with a VBS 2150 propeller and a diameter of 7.6m. System competence makes the difference in any case.

Reliability spare parts kits

MAN PrimeServ's tailored spare parts kits – your shortcut to handling and operating your vessels with peace of mind.

Propeller spare parts kits available

- With the right parts on hand wherever and whenever you need them, you can avoid lengthy stops, last-minute decisions, and rush order handling and associated fees.
- By means of the kit contents and the instructions, crew members can often perform the repair or replacement themselves – and if needed, with support and remote assistance from a MAN PrimeServ propeller service expert.

Components at hand - eliminate risk

- Component failure may cause operational challenges for the vessel.
- Components are known to have fluctuating lead times due to the volatile supply market.
- Can be replaced by crew at sea (with remote support from MAN PrimeServ if needed)
- Components have long shelf-life.
- Does not take up much storage space.

**Keep operations running
between planned dockings**





Features and benefits



ODG (Oil Distribution Gear)
unit with POCVs (Pilot
Operated Check Valves)

Reliable spare parts kits

Swift, simple and safe

To complement spares or maintenance components, we offer complete service packages and spare parts kits to simplify and speed up the job.

Quality of execution

Each spare parts kit is tailored to the specific task, ensuring you have the correct quality-parts in the right quantity ready for installation.

Product targeting

The spare parts kits' contents are assembled to match your installed MAN Alpha CP propellers and propulsion systems. Our spare parts kits consist of strategic spare parts with known supply challenges that have the potential to seriously impair vessel performance.

Expertise and onboard requirements

Our spare parts kits are individually composed and based on the many years of accumulated experience and qualified recommendations from our design engineers, service superintendents and technical experts. Naturally we can accommodate your individual spare parts requests based on which parts you already have available on board your vessels.

Due diligence and peace of mind

The spare part kits were created to ensure that minor component failures cannot lead to major delays and operational problems.

Benefits and peace of mind for you and your crew

- **Genuine spare parts always at hand.**
- **No extra freight charges or rush order fees.**
- **Planned costs lead to long-term savings.**
- **Easy reordering for replenishment.**
- **All-in-all, lowered resource consumption and a reduced carbon foot print.**



What is in a spare parts kit?

A spare parts or maintenance kit from MAN PrimeServ is in general an all-in-one maintenance solution for the exchange of components for engines, GenSets, propellers and propulsion systems. Each spare parts kit contains all the genuine replacement parts required along with installation guidance for the specific component. The installation guide is based on easy-to-follow visual diagrams – enabling your engineers to carry out any required maintenance or replacement correctly and quickly.

Scope of supply

Maker's recommendation

Item	Re-supply time	Failure mode and effects analysis
Servo oil pumps	14 weeks	Dual pump configuration – if one pump fails, vessel will have reduced performance and, depending on propeller system condition, might have problems with pitch control.
High-pressure hoses	6 weeks	Failure of a high-pressure hose will cause loss of local and remote pitch control. Only operation with emergency tools will be available.
Proportional valve	18 weeks	Failure of the proportional valve will, depending on the level of failure, cause loss of remote and local pitch control.
Gaskets	16 weeks	A complete set of seals for internal use – failure includes leaks and loss of, or reduced, pitch functionality.
ASP12 print card	7 weeks	Failure of the ASP12 print card will cause loss of electrical pitch operation (local and remote.)
Pitch feedback sensors	5 weeks	2 identical sensors, wired differently depending on use case: 1) Pitch indication, 2) Pitch control feedback. Failure can cause pitch to move to extreme ahead or astern.
Propulsion control panel	18+ weeks	Failure of propulsion control panel (PCP) will cause loss of remote control functionality (start/stop etc.)
Emergency control tools	10 weeks	Mechanical control tools for emergency pitch operation. This set is mostly found to be incomplete on older vessels.
Pressure control valve	14 weeks	Hydraulic control valve – failure will cause reduced pitch functionality or loss of operation.
Filters	19 weeks	Blocked filters will cause reduced pitch functionality or loss of operation.

- 1 Servo oil pumps – electrical motors
- 2 High-pressure hoses / connections
- 3 Proportional valve
- 4 Gaskets – a complete ‘multi set’
- 5 ASP12 print card
- 6 Pitch feedback sensors
- 7 Propulsion control panel (PCP)
- 8 Emergency control tools
- 9 Pressure control valve
- 10 Filters
- 11 HPU (Hydraulic Power Unit)
- 12 Oil Distribution Unit – ODF example
- 13 CP propeller – Mk 5 example

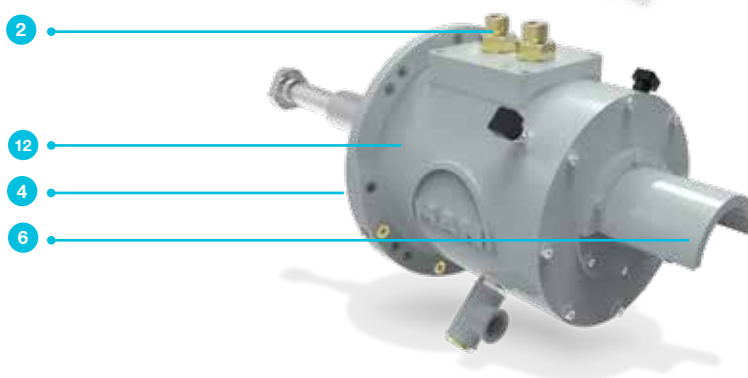
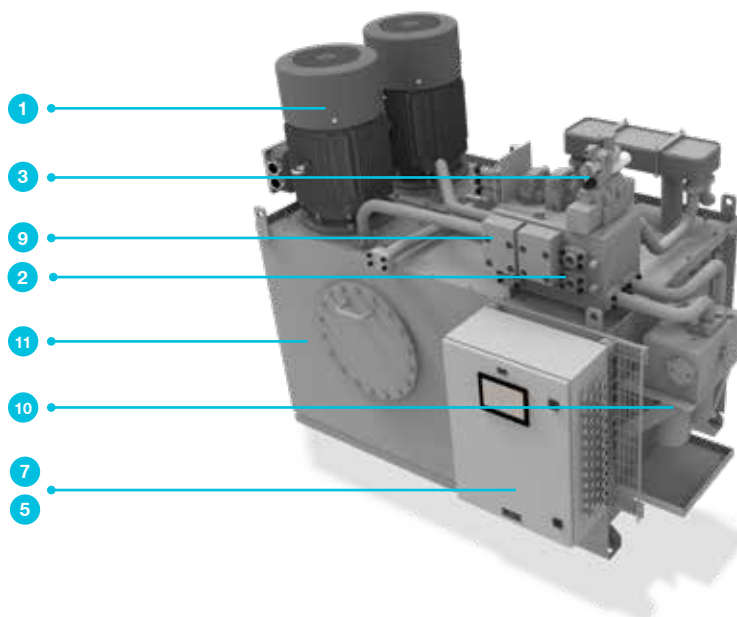

Example of general parts for self-installation - to restore continuous operation quickly.

The parts cover the propeller, servo oil and oil distribution system, HPU (Hydraulic Power Unit) and control system.

Regarding your installed equipment, please note the specific differences between Mk 3 and Mk 5 propeller series, and the oil distribution unit type/location:

- ODS (Oil Distribution Shaft) in shaft line
- ODF (Oil Distribution Front) on gearbox
- ODG (Oil Distribution Gear) in gearbox

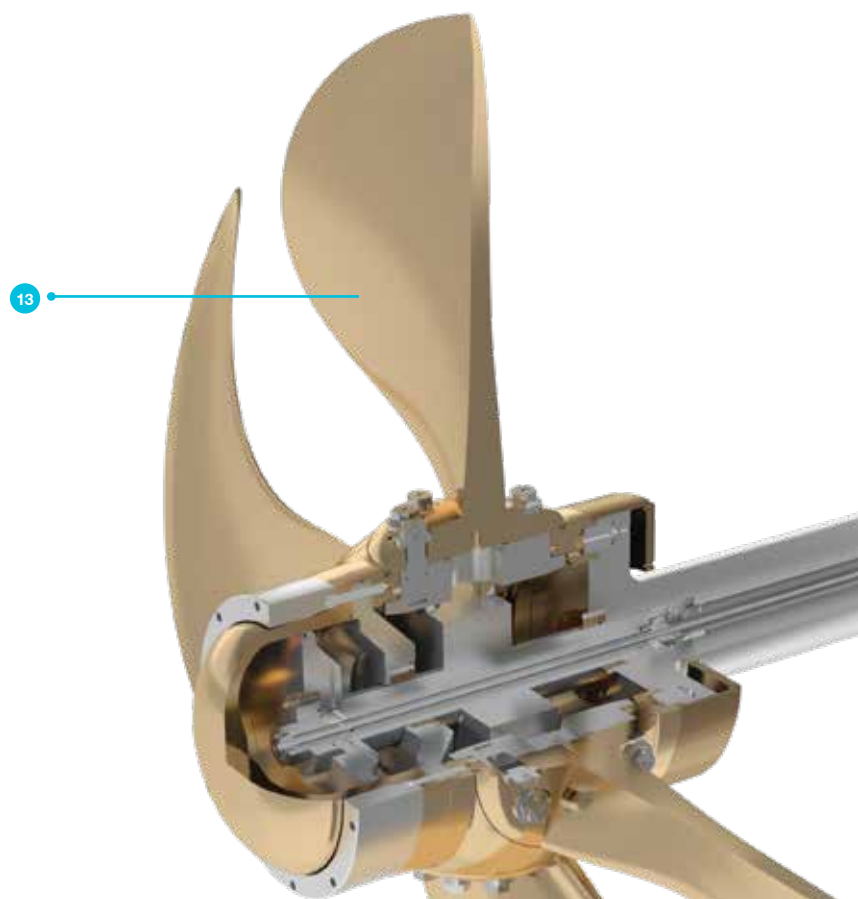

MAN PrimeServ

Service with passion

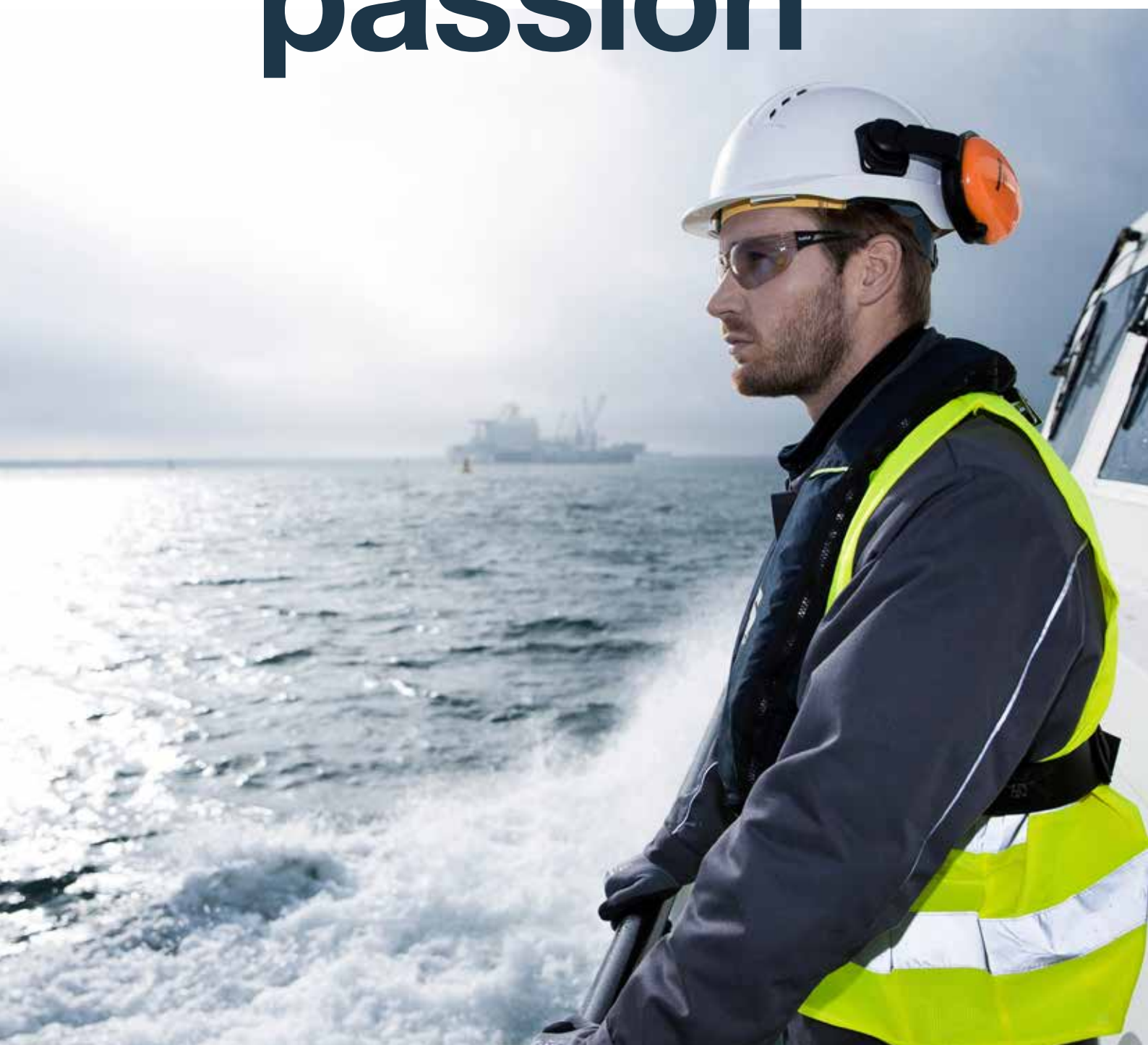



24

hours a day



365

days a year

MAN PrimeServ is the dedicated MAN Energy Solutions service brand. Via a network of over 100 service centers worldwide, MAN PrimeServ provides 24/7 service across the globe. Our range of services includes technical support, consulting and OEM spares, as well as maintenance, repair and individualized service plans like our Propeller Maintenance Concept.

MAN PrimeServ's aim is to provide

- Prompt delivery of high-demand OEM spare parts within 24 hours
- Fast, reliable and competent customer support
- Ongoing training and qualification of operators and maintenance staff
- Global service, 24 hours a day, 365 days a year
- Diagnosis and troubleshooting with our MAN PrimeServ Assist online service

Worldwide service

We offer retrofitting and upgrade services to bring propellers, propulsion systems, engines and turbochargers already in service up to the very latest standards of performance and efficiency.

Using the latest digital technology, we enable you to maximize the performance and availability of your MAN equipment by accessing real-time data analysis, remote support and rapid solutions. We also offer an extensive range of training courses at MAN PrimeServ academies around the world.

Our service does not vary according to location. We know that a vessel may be built in Asia, operated in Europe for ten years and then move to Africa for the next decade. That does not alter our focus on fast delivery of strategic spare parts, a comprehensive approach, or our tailored Propeller Maintenance Concept.

For more information please visit
www.man-es.com/primeserv



100

Service centers
worldwide



Be prepared and keep full pitch ahead

Parts for self-installation – to quickly restore continuous operation
– covering the propeller, servo and oil distribution system, HPU and
control system.

Contact us for your specific equipment: primeserv-frh@man-es.com

Visit the Propeller Maintenance Concept (PMC) website:
www.man-es.com/marine/services/propeller-maintenance-concept

Check list

Item – see details on page 10-11	Quantity available onboard	Current condition, new / used
Servo oil pumps		
High-pressure hoses		
Proportional valve		
Gaskets		
ASP12 print card		
Pitch feedback sensors		
Propulsion control panel (PCP)		
Emergency control tools		
Pressure control valve		
Filters		

MAN Energy Solutions

Niels Juels Vej 15
9900 Frederikshavn
Denmark
P +45 96 20 41 00
F +45 96 20 40 40
primeserv-frh@man-es.com
www.man-es.com

All data provided in this document is non-binding. This data serves informational purposes only and is not guaranteed in any way. Depending on the subsequent specific individual projects, the relevant data may be subject to changes and will be assessed and determined individually for each project. This will depend on the particular characteristics of each individual project, especially specific site and operational conditions.

Copyright © MAN Energy Solutions.
1510-0332-00ppr March 2024
Printed in Denmark.