



Propeller
& aft ship
solutions

Naval propellers

MAN Energy Solutions
Future in the making



MAN Alpha
high-performance
propulsion solutions

Future in the making

MAN Energy Solutions is the world's leading provider of large-bore diesel engines, turbo-machinery, and integrated power systems. We make four-stroke and two-stroke engines for marine and stationary applications, turbochargers and propellers, gas and steam turbines, compressors and chemical reactors. Our marine systems expertise is focused on emission reduction, complete propulsion packages, electrical propulsion, dual fuel, LNG, and digitized services. We are the only manufacturer that serves the whole spectrum of maritime defense applications: from fast patrol boats to large auxiliary ships, from offshore patrol vessels to submarines. No less than 59 navies rely on our engines and propulsion solutions to keep their naval vessels moving.







MAN Alpha naval propellers

**Reliable systems
tailored to meet tough demands**

MAN Energy Solutions is proud to present a naval propeller and aft ship program which has been developed on the basis of the industry's state-of-the-art design and optimization tools combined with the vast experience accumulated from more than 7,500 propellers. A long tradition and a grand heritage with propellers developed for both commercial and military marine applications, dating back to the first Alpha controllable pitch design which was produced in 1902 and patented in 1903.

Our target is to provide flexibility to efficiently cover any propulsion requirement in the 2-50 MW shaft power range. 3-, 4- and 5-bladed propeller configurations are available. The optimized propeller performance from controllable pitch propellers (CPPs), fixed pitch monoblock propellers (FPPs) and FPPs with replaceable blades, and adjustable bolted propeller designs with tailored blade configurations contribute to powerful and energy-efficient missions with a reduced impact on the environment.

- **Highest propeller performance**
- **Reduced hydroacoustics**
- **Increased flexibility**
- **More modes of silent operation**
- **Greater fuel savings**
- **Lowest total cost of ownership**

View of product line examples



The MAN Alpha propeller program offers excellent coverage of navies' propulsive power and reliability demands.

Today, a wide range of naval and patrol vessels are propelled by our propellers and propulsion solutions – ranging from powerful combat frigates, command support vessels and offshore patrol vessels to coastal supply cutters.

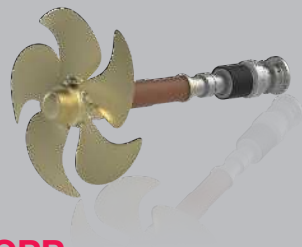

CPP
Open free-running

Performance designs

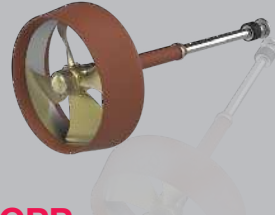

CPP
Ducted - nozzle operation

Pulling power designs



CPP
EcoBulb operation

Economy cruiser designs

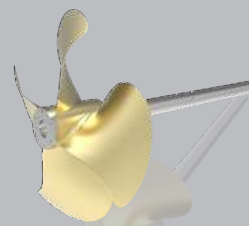

FPP
Flanged hub/shaft

Mono-block designs

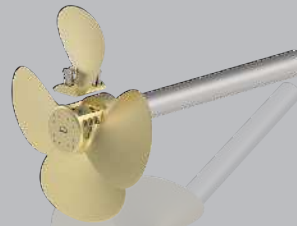

FPP
Replaceable blades

Robust designs for extreme conditions

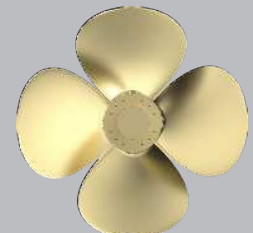

FPP
Adjustable & replaceable

OPV designs

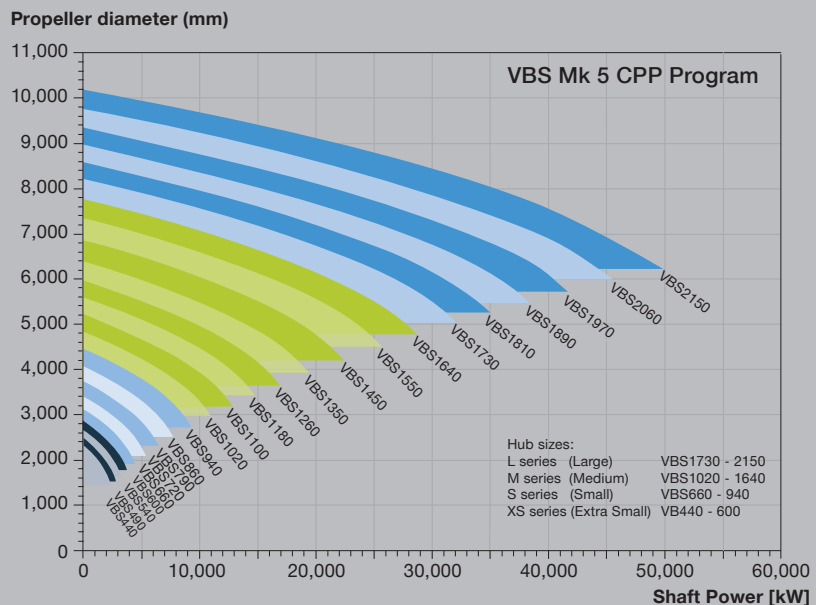

Hub model/size indication for guidance only – free running propeller operation

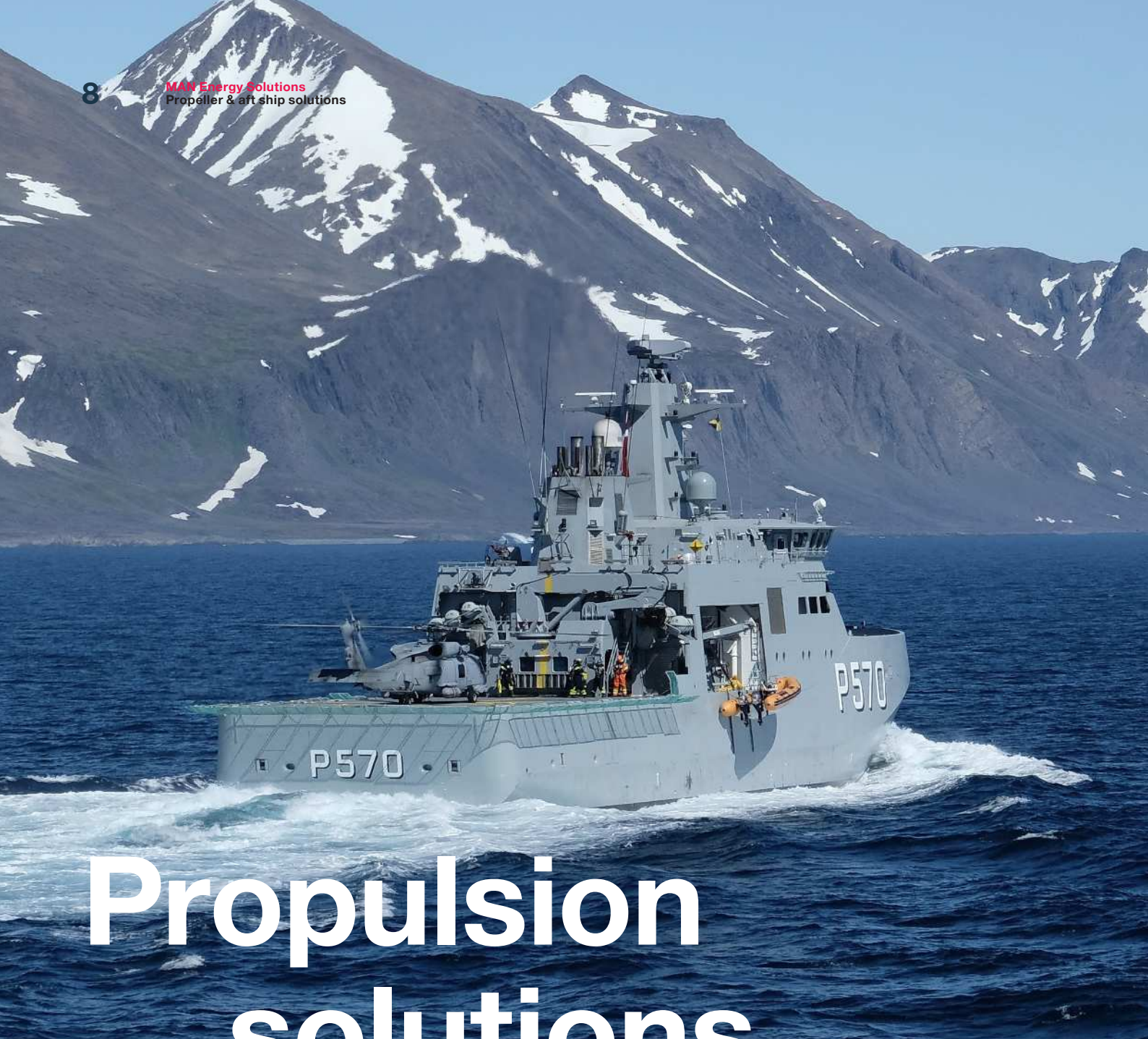

Propulsion solutions and application flexibility

Designs tailored for naval missions

Complete solutions for versatile power and propulsion designs

Propeller installations are customized for various propulsion application combinations with MAN low-, medium- and high-speed engines in a wide range of single- and multi-propeller diesel-mechanical, hybrid/battery-hybrid or diesel-electric propulsion setups.

The more complex and performance-demanding naval applications are typically optimized for extreme conditions, many operational mode conditions from silent to sprint steaming including additional gas turbine propulsion power units.

CODAD

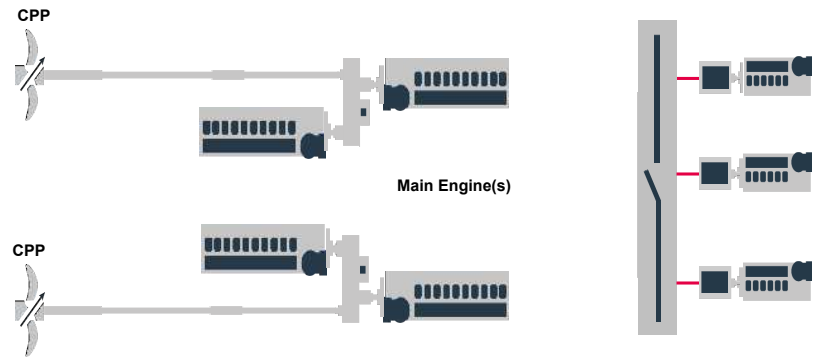

CODOG

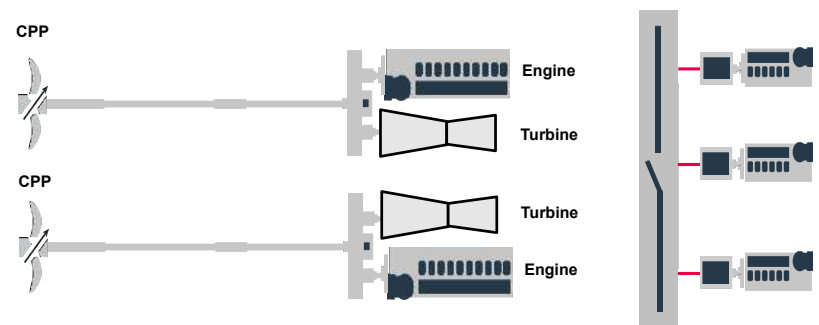

CODAG

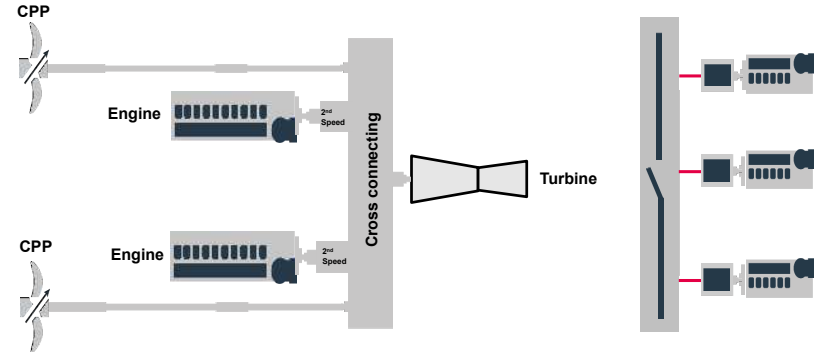

TISO

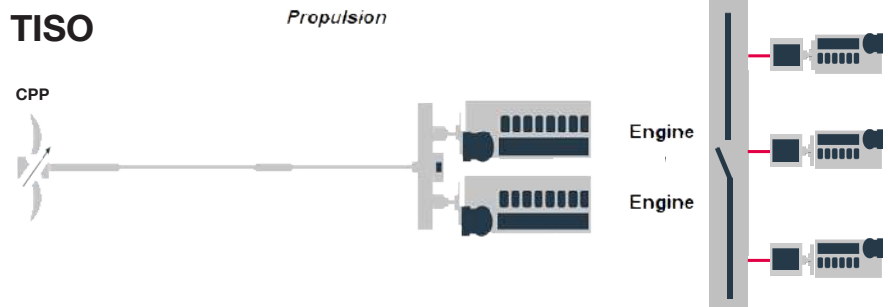

Increased propulsive efficiency

Hydrodynamic
competences in naval force



To maintain and develop MAN Energy Solutions' position at the forefront of propulsion, many resources are invested and the latest advanced design tools are deployed, including e.g. CFD (Computational Fluid Dynamics), FEM (Finite Element Methods), BEM (Boundary Element Methods) and System Simulation. To verify the calculations, MAN Energy Solutions cooperates with technical universities and the world's leading model test and research institutes.

Hydrodynamic design characteristics

- Maximized efficiency with due respect to controlled cavitation, pressure impulses, vibration and noise
- Skew, rake, area-ratio and blade number (3-4-5) parameters are all balanced and efficiency-optimized
- The shape of the hub is flow-optimized and reduced in size, resulting in a low drag
- The flow optimization includes a streamlined shape of the hub and blade integration
- As always, the propeller designs are optimized to the individual ship application and mission profile.

Operational advantages

Increased propeller efficiency translates into savings via lower fuel consumption, reduced exhaust gas emissions – or may be exploited as higher thrust for increased ship speed for a given engine power.

Benefits of the MAN Alpha propellers

- Highly efficient hydrodynamic design
- Lower propeller-induced pressure impulses
- Reduced risk of cavitation – high blade loading possible for demanding applications.

Hydrodynamic integration and optimization

The perfected layout and hydrodynamic propeller integration are always optimized with the ship's hull and any 'flow-guiding and efficiency improving devices' placed before the propeller, e.g. pre-swirl fins and vortex-generators. After the propeller, the optimization can consider high-efficiency rudders, integrated EcoBulb rudder bulbs, post-swirl fins or similar.

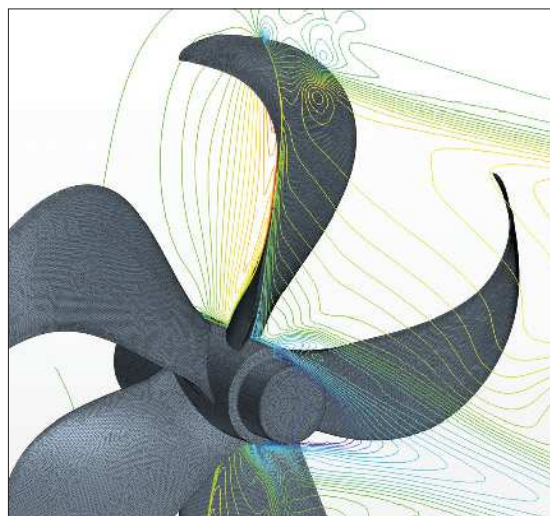

CFD streamlines during operation



High blade loading simulation – reduced root cavitation below

Low noise levels and high performance

Innovative Kappel 2.0 propeller blade design

With the advanced Kappel 2.0 propeller blade design, MAN Energy Solutions perfectly meets the demands of navies for low noise levels without compromising propulsion performance.

Design principles

Cavitation is the dominant factor when it comes to propeller noise. Therefore, effective control of cavitation is crucial. For the Kappel 2.0 blade design, rake, camber, pitch and chord length in the tip region are optimized for minimized cavitation and increased cavitation inception speed (CIS) while maintaining propulsive efficiency.

Benefits of the Kappel 2.0 propeller blade design

- Increased cavitation inception speed (CIS) for lowest acoustic signature while operating in silent mode
- Reduced cavitation and low levels of propeller noise and vibration during operation at design speed.

Design methods

- Analysis of the local tip flow and optimization using high-fidelity CFD simulation methods
- Cavitation analysis and cavitation inception speed (CIS) prognosis using CFD and BEM with advanced cavitation models
- Noise radiation simulation using CFD and BEM approaches tested and developed in cooperation with tank test institutes and technical universities.

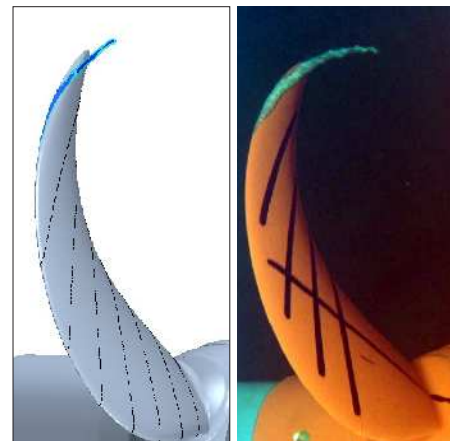

Reliable simulation methods: CFD cavitation prognosis (left) and observation during experiments (right)



Even though each propeller design is unique, a Kappel 2.0 blade can easily be recognized by its characteristically bent tip

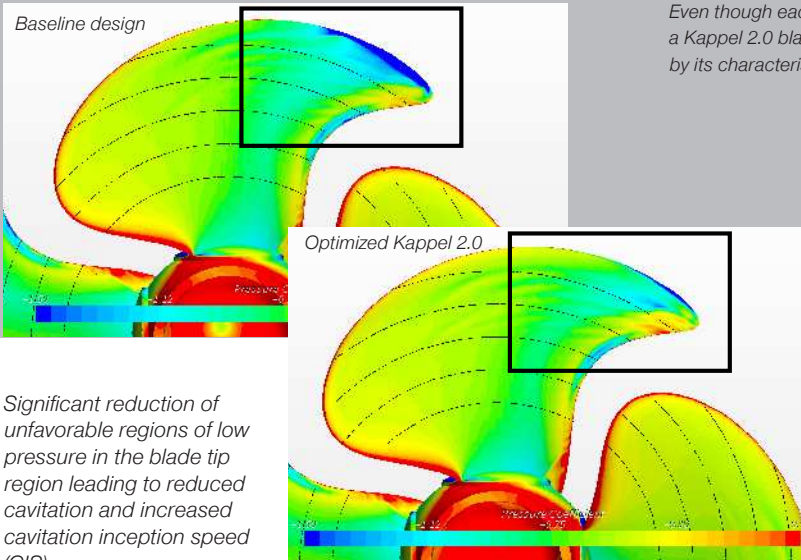

Significant reduction of unfavorable regions of low pressure in the blade tip region leading to reduced cavitation and increased cavitation inception speed (CIS)

Holistic design approach

For highest demands with respect to propeller noise and cavitation inception speed (CIS), it is recommend to consider propeller, rudder, rudder bulb, struts and hull lines as one unit. The experienced propeller designers of MAN Energy Solutions provide guidance during the whole project – from initial design concepts at the start to sea trials at the end.

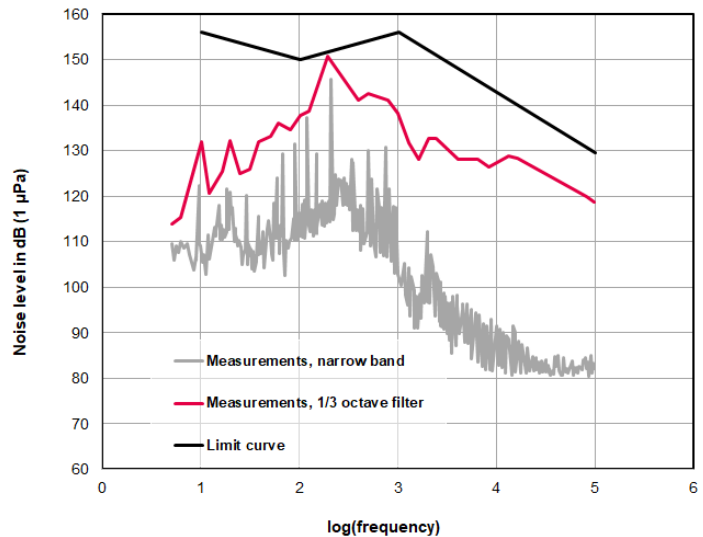

Noise requirements fulfilled: URN spectrum of a vessel equipped with propeller and main engine from MAN Energy Solutions - measured during sea trial



Reliable propeller designs

**Mechanical robustness
for safe long-term operation**

The hubs are designed and optimized for specific operating profiles with due consideration for the propeller/shaft torque, material properties and weight. The MAN Alpha propeller reliability and durability have always been very high, and the latest generation of CPP and FPP designs follows that philosophy.

Mechanical design characteristics

- Robust approach – with ample design margins
- As standard, the propeller material is specified as Ni-Al-Bronze. Other material available upon request
- Material fatigue levels are calculated for a 30-year lifetime, considering all possible external loadings in service
- Designed for ice operation according to the newest IACS and FSICR ice class notations
- Ice loadings include the influence of ice milling on the complete system's torsional response
- Compact hub/blade root design and low weight ensuring well-balanced load distribution
- Optimized for reduced material stresses during normal operation and extreme loads
- Shock resistant component designs analyzed and documented to current military standards.

More speed and power featured

Novel hub, blade and blade foot design advantages:

- Higher inflow and cavitation inception speed
- The 'multi-radius-fillet' design reduces the blade weight by approximately 4% and contributes to a higher cavitation inception speed
- The optimized hub/blade interface allows for higher propulsion power densities.

Operation and service advantages

- Low wear rates and very long lifetime
- Higher reliability with few components
- Reduced bearing loads due to low weight
- Smaller hub dimensions resulting in high efficiency
- Large pitching range and great maneuverability
- Serviceable from aft – providing increased dismantling, service and inspection friendliness
- Exchangeable blade flange bearings.

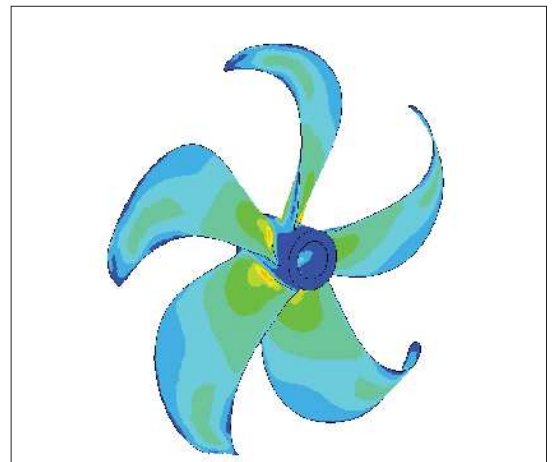
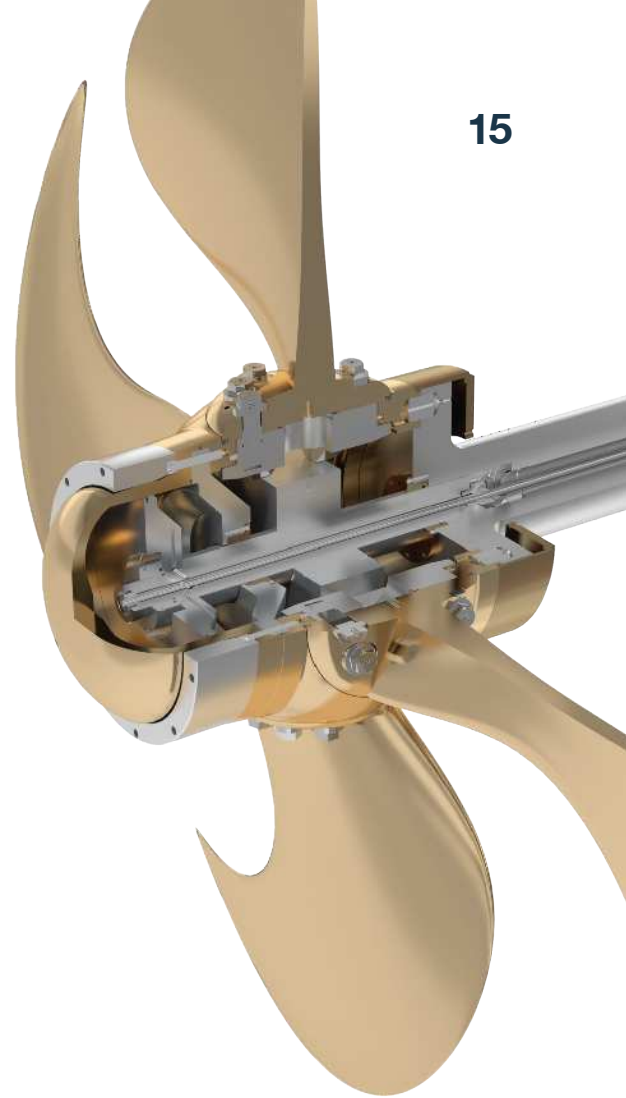

Blade roots Von Mises stresses in wake field, normal loading



Propeller designs strengthened for the highest ice classes

Plant competence and added value for customers

Perfect tools and know-how
for integrated solutions

Tailored propeller systems and stern tube designs: compact and optimized installation dimensions are ensured in consideration of e.g. ships' hull shape, struts, rudder arrangement, engine room, shafting and stern tube equipment.

COPS – a unique layout tool

COPS is an abbreviation for Computerized Optimization of Propulsion Systems. MAN Energy Solutions' COPS expert system ensures better and more accurate pre-optimization of hydrodynamic/mechanical aspects, integrating e.g. statistical data, torsional vibration data of the complete propulsion system including main engine parameters.

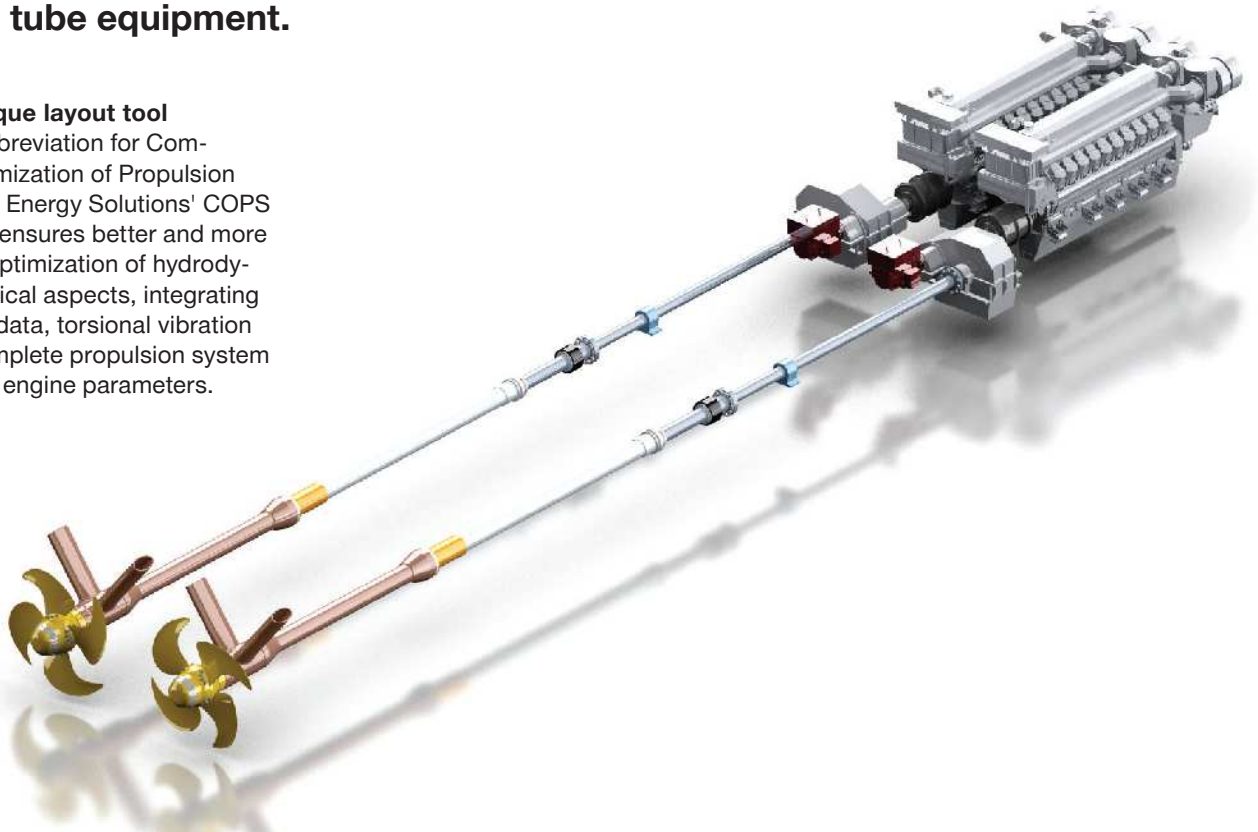



The propeller range offers excellent coverage

The propellers handle outputs from 2,000 to 50,000 kW per shaft. Multiple propeller solutions are available for direct coupled, geared diesel-mechanical, diesel-electric, hybrid/battery-hybrid and combined propulsion plants.

Optional equipment and special installation requirements

MAN Energy Solutions masters a vast number of disciplines in relation to optimization of aft ship parameters and special installation requirements, such as:

- Rudder design interaction
- Integration of EcoBulb rudder bulbs
- Propeller strut design integration
- Guide vanes for wake field improvements
- Shaft brake and locking devices
- De-magnetization of propeller shafts.

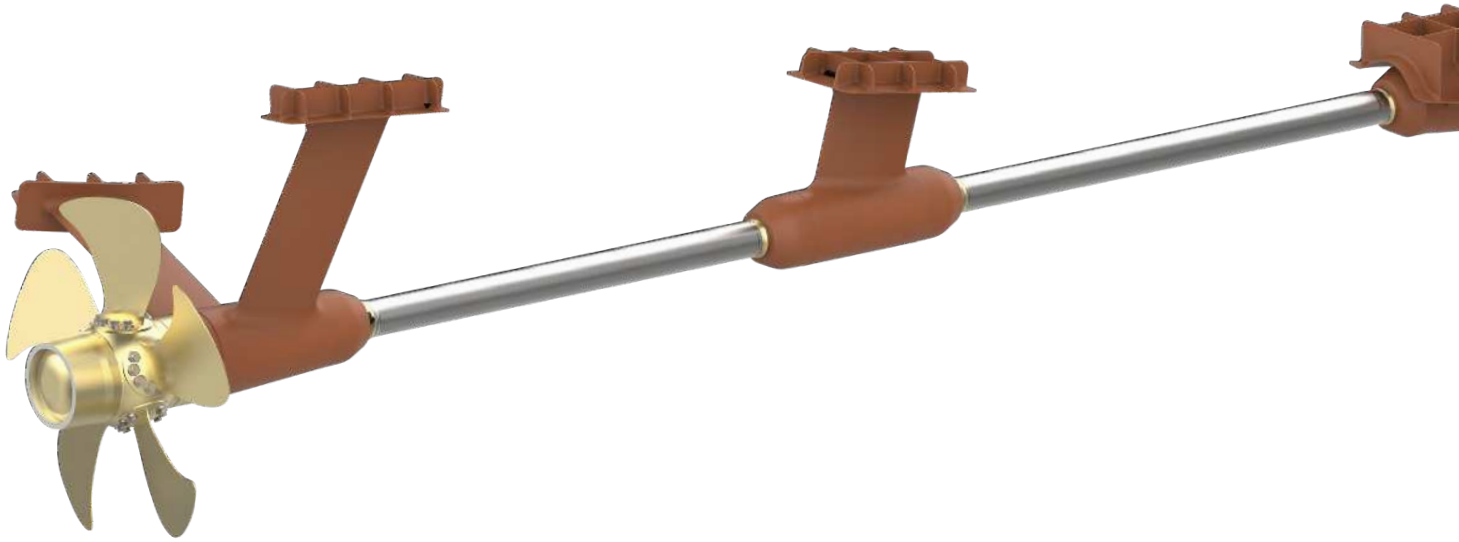

Customized propeller and aft ship solutions

**Supreme execution for
special naval requirements**

**System competence makes the
difference in every situation**

We have accumulated a vast knowledge and development base during our many years with focus on the specification, design, optimization, sales, order processing, supply, commissioning and after sales servicing of complete propeller and propulsion systems.

Today's core portfolio of propeller and aft ship products and system solutions integrates perfectly with the wide range of MAN Energy Solutions high-speed, medium-speed and low-speed engine designs.

Tailored solutions are available for individually optimized applications ranging, for example, from a MAN 175D high-speed powered patrol boat, and a MAN 28/33D medium-speed powered frigate to a MAN B&W two-stroke low-speed powered logistic supply vessel.

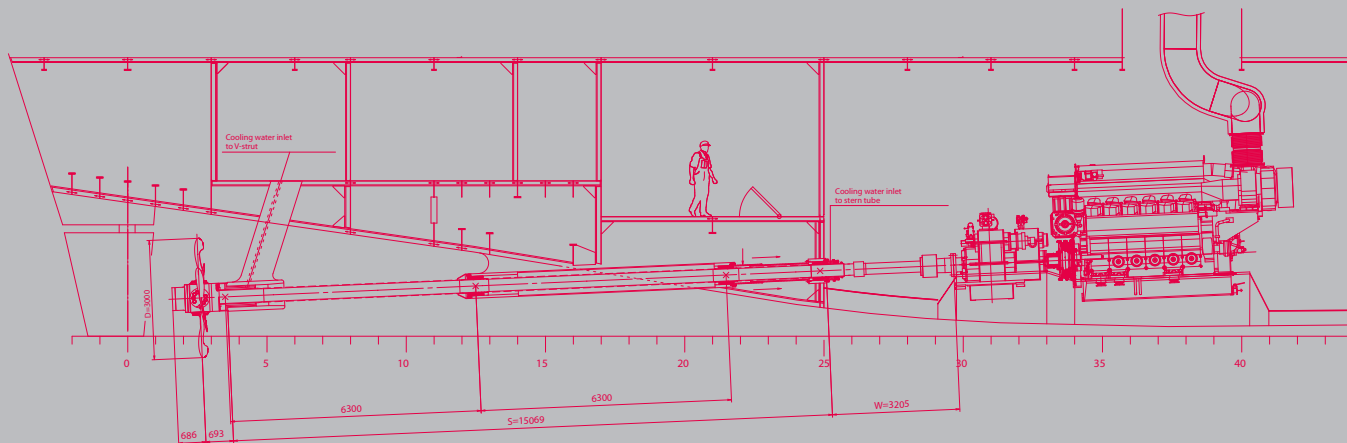
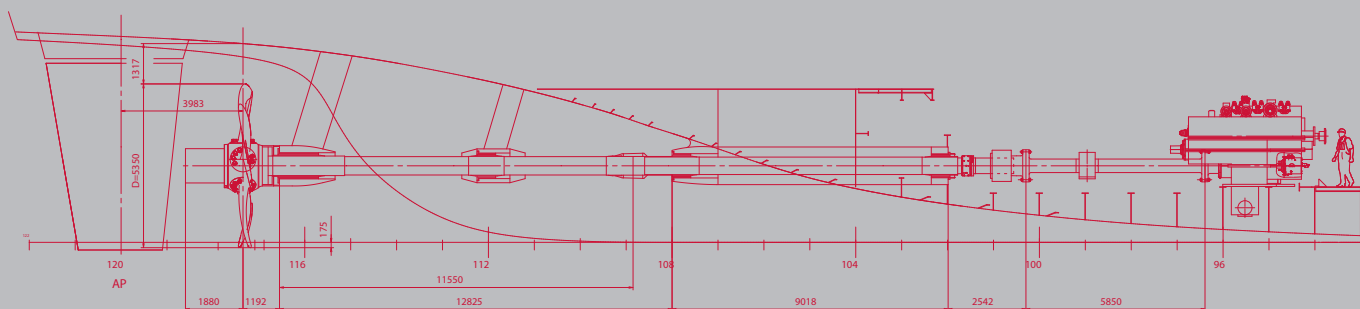
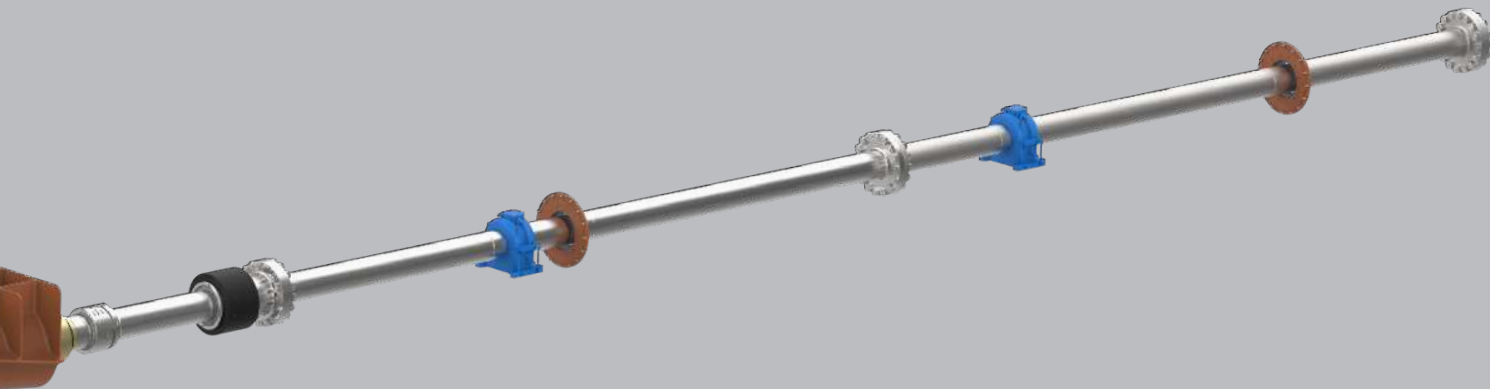



Shafting, struts and stern tube merits

Cladded shafts - overlay welding

Our inhouse Submerged Arc Welding (SAW) plant ensures a very stable and high-quality clad welding process with a high deposition rate. Cladding is a welding process that allows for a functional metal layer to be deposited on the surface of another, often inferior, tail shaft metal.

Cladding benefits at a glance

- Strong and more durable coating compared to epoxy shaft coating
- More cost effective than a solid stainless steel shaft
- For exposed shafts, no risk of damaging epoxy coatings from wires and debris in the water
- Smaller shaft/bearing diameters
- Easy and quick to refurbish.

Customized stern tube solutions

Water-lubricated stern tube systems are today often selected and tailored for naval propeller installations – including our compact and easy to install Alpha Water Treatment (AWT) units.

The optional oil-lubricated stern tube systems are adapted to both biodegradable oils and ordinary mineral oils. Switching from one oil type to the other is possible without any requirements for component changes.

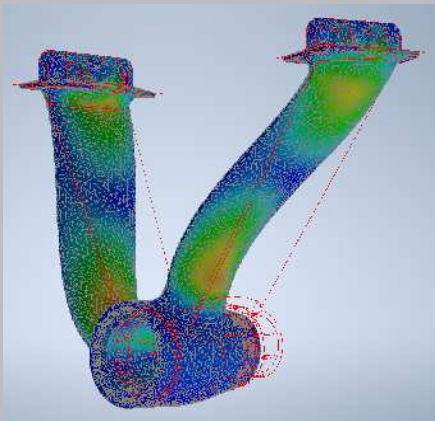
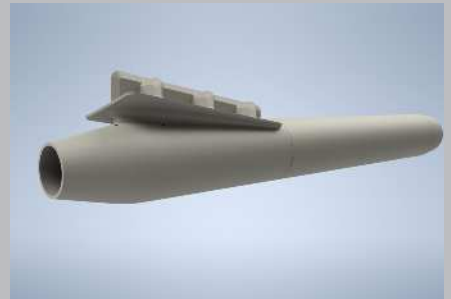
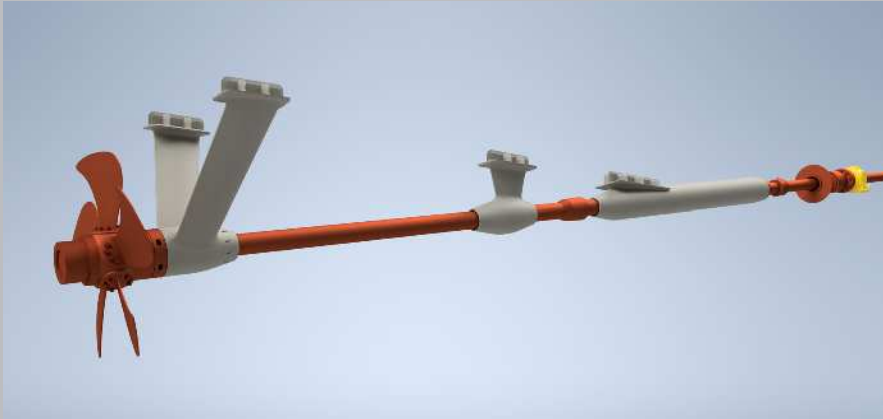

Strut integration and alignment

A-brackets, I-brackets and stern tube boss - all the parts and the completed propeller and shaft system design are selected on the basis of:

- CFD simulations for global system optimization
- Integration of propeller blade design, propeller hub and tailshaft
- Integrated propeller blade number in way of strut bracket angles, bracket profiles and position for best possible wakefield for the propeller.

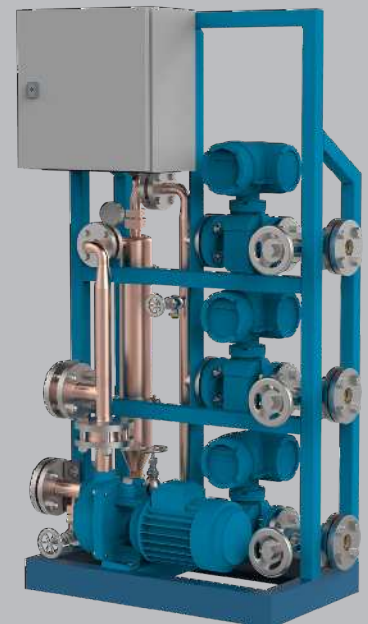
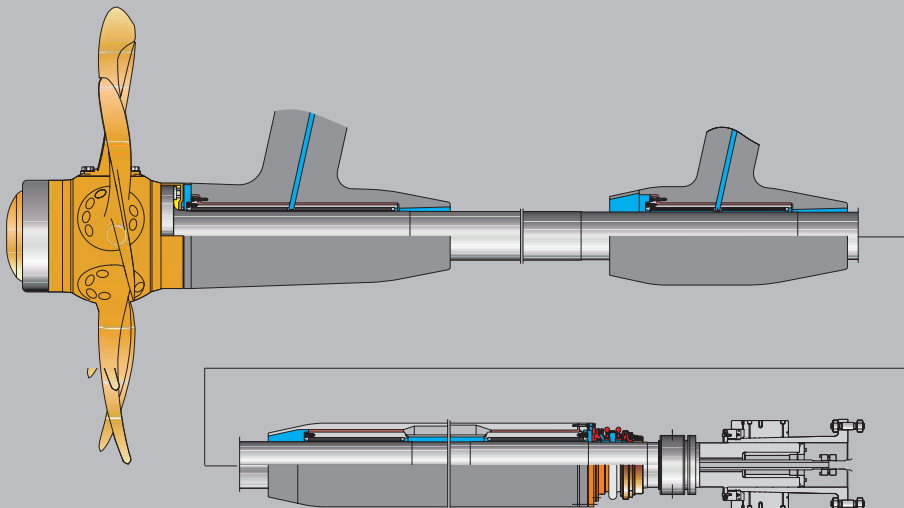

CPP maneuverability - swift and safe

Robust servo control systems



Hydraulic power unit (HPU)

The hydraulic power unit offers high-volume hydraulic modes ensuring optimal maneuvering and 'crash stop' opportunities. As standard, a unit features electrically driven pumps, suction filter, duplex full-flow pressure filter, proportional valves, servo pressure adjustment valve, cooler, alarms, monitoring sensors and display.

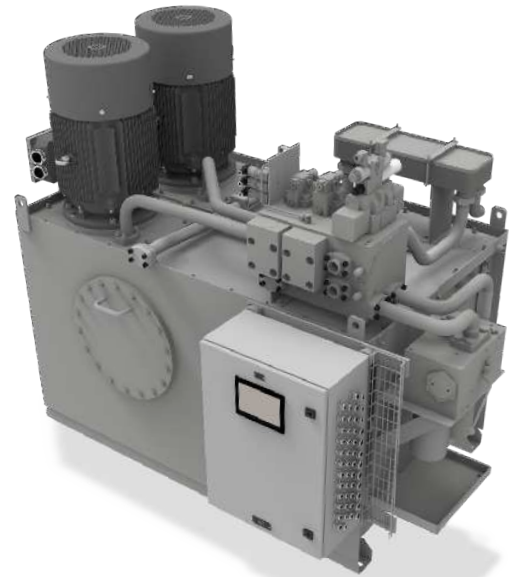

ODF oil distribution unit

A very compact ODF oil distribution unit has been developed for gearbox mounting. A short and very robust unit with 20% fewer parts compared with today's ordinary ODF designs. The installation length has been reduced by 22% – for the benefit of very short and compact engine-gear-propeller installations – still with the necessary access and ease of servicing.



Fast propeller blade pitch changes and safe maneuvers are possible due to a 28% higher pitching torque for a given propeller hub size – compared to previous designs.

Extreme degraded conditions and emergency operation - in flooding, inclination and black-out

Flooded engine room compartment

To ensure continued and safe operation in the extreme event of flooded compartments, choose our optional special watertight equipment tested and accepted for 5 m water depth submersion for 48 hours. Further special features for watertight requirements are possible via our design integration.

Servo system for black ship operation

In order to maintain propeller pitch control and continued propulsion in the event of auxiliary machinery malfunction and/or electrical black-out, mechanically driven servo oil pumps can be integrated in the design – typically fitted to and driven off the main gearbox or main engine.

Cross-over between engine rooms

The optional propeller pitch servo oil emergency operation cross-over functionality makes it possible to control the pitch of the opposite side propeller system - in the event that the hydraulic power unit (HPU) on that becomes inoperable.

Smooth, quiet and powerful convoy steaming

Synchronized navigation for special missions





Preparing replenishment at sea (RAS operation) while under way

Replenishment at sea - coordinated propulsion

Side-by-side operation for re-fueling activity without delaying transit navigation. Replenishment at sea (RAS - NATO) or underway replenishment (UNREP - US NAVY) is a method of transferring fuel, munitions, and stores from one ship to another while under way. It requires precise speed and navigation synchronization between ships.



Full feathering propellers

Our CPPs with full feathering option offer special operational modes with optimal pitch setting for e.g. economical sailing or convoy cruising with one propeller engaged and the other disengaged in full feathering position for 'minimal resistance'.

Power and fuel savings

A recent comparison study showed remarkable power savings with the disengaged propeller in full feathering position:

- The locked propeller (versus full feathering) required 48% more power at 9 knots
- The windmilling propeller (versus full feathering) required 18% more power at 12 knots.



Shock excitations, design precautions and testing



Full-scale shock testing – from underwater explosion

Calculations and analysis of propeller, shaft system and propulsion electronics

Shock excitation in electronic propulsion control equipment

Shock requirements can be considered in the design for which, as an example, our global approach goes all the way and includes the Alphatronic propulsion control system. Here, shock load tests are performed with certification for panels passing 10 G in 10 ms, cabinets 20 G, and sensors (pitch feedback, tach) up to 320 G in 3.3 ms.

Shock excitations in the shaft lines

A complete MAN Alpha propeller system can be designed and documented to any shock requirements.

A full shock response analysis is carried out for the complete scope of supply in accordance with current military standards.

This serves to ensure that all mission critical components are designed with ample safety margins against underwater shock influence.

Controlled torsional vibrations

A MAN Alpha shafting and propeller system will be optimized, adjusted and documented to ensure safe operation. The optimization will be done by proper modifications to the main engine tuning, flexible couplings or shaft line dimensions – taking the total cost structure of the complete plant into consideration.

Controlled shaft line whirling vibrations

The whirling vibrations are generally non-critical for single screw installations, but may cause problems for long and slender shaft lines' characteristics for twin screw vessels. Fully excited, whirling vibrations may lead to critical structural vibrations and shaft bearing and stern tube seal problems. Whirling vibrations may be counteracted by proper layout of the shaft line and its bearings based on analysis and our extensive experience with complex propulsion systems.

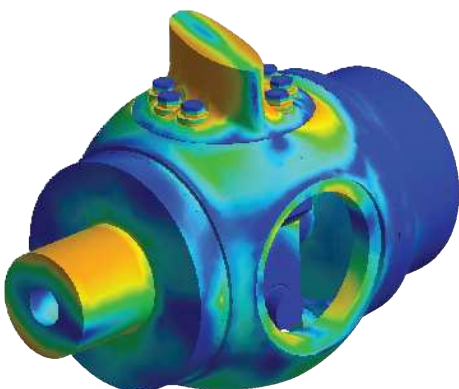

FEM analysis: propeller hub assembly subjected to simulated shock from underwater explosion



Shafting: Struts, bearings and an Inconel clad-welded tail shaft



Shock resistant HPU

and an ODF oil distribution unit prepared for flooded compartment operation: the ODF design includes a unique 100% linear feedback system – a contactless ultrasonic design with no use of linkage bars. No wear and no hysteresis in feedback.

Alphatronic 3000

**Power and maneuverability
– right at your fingertips**



**Ship propulsion
command and
control system**

Reliable and accurate propulsion control all the way – from the navigator's finger tips to the propeller tips. Any maneuvering order given is translated into electrical speed setting, pitch or clutch signals, governing the hydraulic servo circuits of engine/gearbox and propeller systems.



The Alphatronic 3000 Propulsion Control System offers an unrivaled “Human to MAN” interface with ergonomically logical and clear layout of panels, levers, buttons, displays and touch screens ensuring safe and efficient maneuver interactions. Alphatronic 3000 controls both

straightforward CP Propeller and FP Propeller installations and can be customized for various propulsion application combinations with MAN low-, medium- and high-speed engines in a wide range of single- and multi-propeller diesel-mechanical, diesel-electric or hybrid propulsion setups.

PrimeServ Assist online service
PrimeServ Assist remote monitoring and optimization combines the latest digital technologies with MAN’s expertise – for maximized equipment availability, safety, and efficiency. MAN experts connected via a global network ensure proactive PrimeServ Assist services around the clock.

On top of any situation

Maneuvering capability matters
when the going gets tough



Propulsion system mode selection – examples

- Economy cruising
- High-speed cruising
- Combat mode
- Loitering mode
- Convoy sailing and RAS operation
- Silent operation, low-speed cruising
- Silent operation, anti-submarine warfare

Logistic support pack

Safeguarding naval demands



ILS - Integrated Logistic Support

Enhanced effectiveness, product availability, service - and supportability

ILS for the full life cycle

MAN Energy Solutions provide logistics services which keep equipment optimized and ensure system readiness for the duration of naval vessels' operational life at the lowest possible life-cycle cost.

In close cooperation with our naval customers, a wide range of integrated logistics support (ILS) services are tailored to support the acquisition, introduction, commissioning, operation, modification, and disposal of major assets in the propulsion drivetrain and propeller and aft ship system of naval vessels. Our approach employs the latest generation life-cycle material management and system engineering techniques based on a full conception of operations - using advanced computer tools and information technologies.

Logistic packages

The PrimeServ organization's products and services are largely presented as user-friendly kits offering the highest degree of product safety, top quality spare parts and the availability of correct amounts - together with associated 'work card' instructions.

Academy training

PrimeServ Academy training for operational staff PrimeServ Academies are competency centers for product training with the focus on design, operation and maintenance of propulsion engines, gensets, gearboxes, propellers and remote control systems.

ILS tailored within six core modules

- Data and analysis
- Packaging, handling, storage and transportation
- Technical documentation
- Training
- Spares
- Long term service

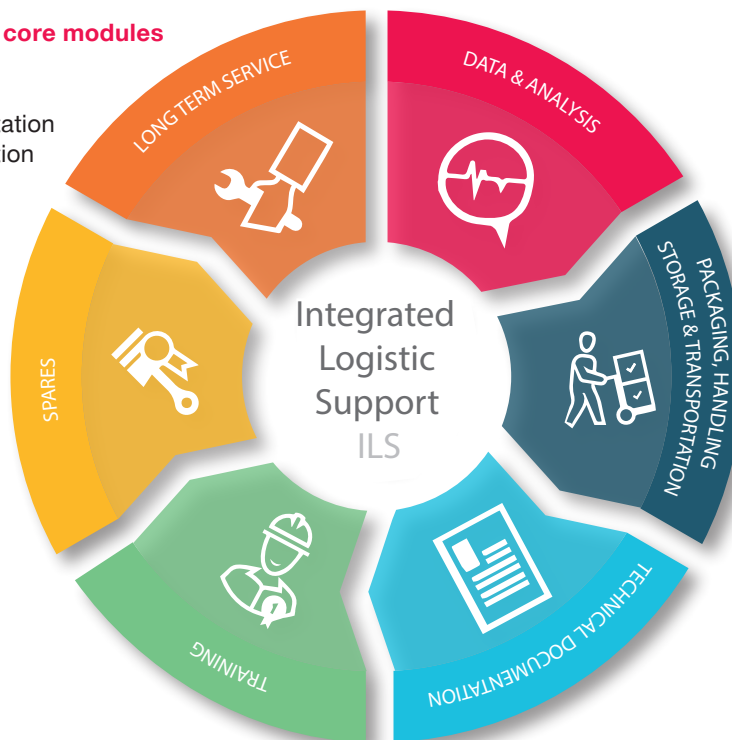

Propeller Maintenance Concept

The MAN Energy Solutions service brand MAN PrimeServ offers after-sales service for the entire range of MAN products from spare parts supply, technical service, re-conditioning and retrofit, to propeller maintenance concept (PMC) service packages. The PMCs are offered in connection with 5 and/or 10 year inspections - in accordance with the docking periods recommended by the classification societies.

MAN PrimeServ

Service with passion



MAN PrimeServ is the dedicated MAN Energy Solutions service brand. Via a network of over 100 service centers worldwide, MAN PrimeServ provides 24/7 service across the globe. Our range of services includes technical support, consulting and OEM spares, as well as maintenance, repair and comprehensive individualized service plans.



365

days a year

24

hours a day



MAN PrimeServ's aim is to provide

- Prompt delivery of high-demand OEM spare parts within 24 hours
- Fast, reliable and competent customer support
- Individually tailored O&M contracts
- Ongoing training and qualification of operators and maintenance staff
- Global service, 24 hours a day, 365 days a year
- Diagnosis and troubleshooting with our high-performance MAN PrimeServ Assist online service



MAN Energy Solutions



MAN Energy Solutions and legacy brands

MAN PrimeServ is our brand name for high-quality aftersales support for the entire MAN Energy Solutions product portfolio. Through refinements to our products and repair techniques, we ensure and enhance our technological leadership and technical expertise as an Original Equipment Manufacturer (OEM) for the brands united under MAN Energy Solutions.

Worldwide service

We offer retrofitting and upgrade services to bring propellers, propulsion systems, engines and turbochargers already in service up to the very latest standards of performance and efficiency.

Using the latest digital technology, we enable you to maximize the performance and availability of your MAN equipment by accessing real-time data analysis, remote support and rapid solutions. We also offer an extensive range of training courses at MAN PrimeServ academies around the world.

Naval forces must always be ready for action and so is our service team, offering continuous support, dedicated training, and fast delivery of spare parts wherever your military operations take you.

For more information please visit
www.man-es.com/primeserv



100

Service centers
worldwide



Get in touch and propel ahead

Propeller & Aft Ship

Website for more naval propeller information, contacts and downloads.

**Propeller Maintenance Concept**

Learn about our PMC - protect your investment and stay competitive

**Retrofit & Modernization**

Learn more about propeller upgrading and benefits.





- CP Propellers since 1902 -

Discover more on our websites
man-es.com | manalpha.com

MAN Energy Solutions

Niels Juels Vej 15
9900 Frederikshavn
Denmark
P +45 96 20 41 00
info-frh@man-es.com
www.manalpha.com
www.man-es.com

All data provided in this document is non-binding. This data serves informational purposes only and is not guaranteed in any way. Depending on the subsequent specific individual projects, the relevant data may be subject to changes and will be assessed and determined individually for each project. This will depend on the particular characteristics of each individual project, especially specific site and operational conditions.

Copyright © MAN Energy Solutions.
1510-0201-02ppr October 2022
Printed in Denmark.