



# ME-GA

**MAN Energy Solutions**  
Future in the making

The latest dual-fuel MAN B&W two-stroke engine

# Future in the making



# Contents

Introducing the world's first MAN B&W ME-GA engine	05
Commitment to the development of new technologies	06
ME-GA complements successful ME-GI and ME-LGI engine programme	06
An optimised Otto principle and its characteristics	07
Introducing the premixed Otto principle	07
Differences in engine performance related to Otto and Diesel cycles	07
ME-GA engine development adapted to the customer	09
Engine configuration	09
Exhaust gas recirculation optimises engine performance	09
Exhaust gas recirculation is integrated into the engine tuning	10
The ME-GA solution	11
Fuel gas specification	11
Fuel supply to the engine	11
Unique on-engine gas admission concept	11
Fuel ratio control	14
Piston ring package ensures even pressure distribution	15
Installation aspects	16
Fuel gas supply systems	16
ME-GA engines and shaft generators	20
PTO layout limit	20
Rpm/governor stability	20
Summary	21
Acronyms	22
Bibliography	22

**MAN Energy Solutions has added the dual-fuel ME-GA engine to the existing two-stroke dual-fuel engine programme. The ME-GA engine design concept is the premixed Otto principle, and the efficient performance of the engine is the result of an in-house developed exhaust gas recirculation (EGR) solution. The high-pressure EGR solution has been optimised for the ME-GA engine with performance-enhancing results, which include high performance efficiency, significantly reduced methane slip, and Tier III compliance when operating on conventional fuel oils.**

**Moreover, the development of the ME-GA engine solution, which requires only a low-pressure fuel supply, has been performed with focus on reducing capex for certain ship designs in the LNG carrier segment. This paper introduces the unique on-engine gas admission system, and discusses the new engine optimisation achieved with the proven EGR system.**

**The first ME-GA engine available in our engine programme is a 70-bore engine aimed at the LNG carrier segment.**

## Introducing the world's first MAN B&W ME-GA engine

On 18 March 2021, a live demonstration of the world's first MAN B&W ME-GA engine took place during a virtual event at the Research Centre Copenhagen. Different engine running conditions, including the enhanced performance by means of EGR were among the key

subjects highlighted and demonstrated at the event.

GA is an acronym for gas admission, and the ME-GA engine is an internal combustion engine (ICE) based on an EGR-optimised version of the

premixed Otto principle. The development process of this new engine type has included a series of tests on one of the two engines at our research facilities in Copenhagen, before the factory acceptance test (FAT) of the first production engine.

The test results verified our requirements to the commercial engine design. In addition, a five-month R&D test series on the first commercial engine will be completed before the delivery of the first commercial ME-GA engine in the summer of 2022.

In 2019, MAN Energy Solutions revealed main data for the first ME-GA engine, the two-stroke MAN B&W G70ME-C10.5-GA, see the ME-GA engine project timeline in Fig. 2.

Since the introduction in March 2021, more than 180 x G70ME-C10.5-GA EGR engines have been ordered as per July 2022, and the engine design has proven its popularity in the LNG carrier segment.

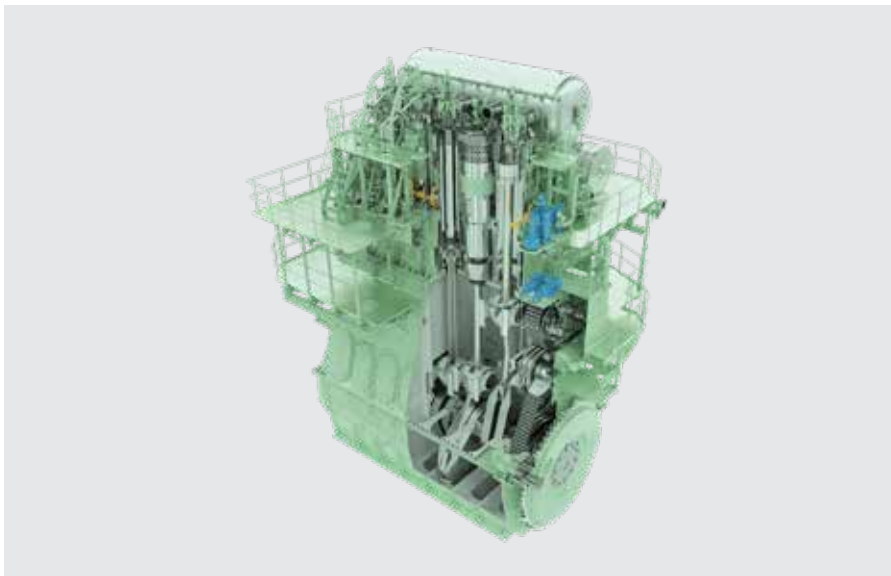

Fig. 1: The MAN B&W ME-GA engine

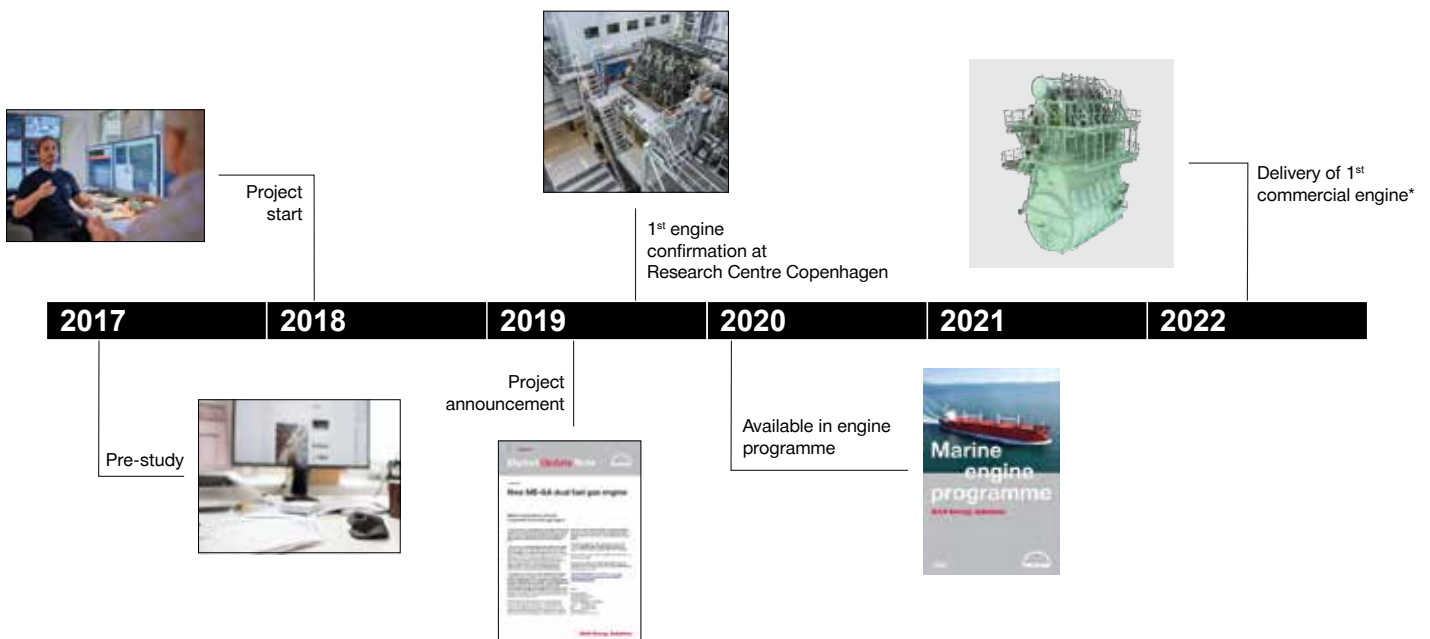

Fig. 2: Project timeline for the ME-GA engine development

### **Commitment to the development of new technologies**

As a technology provider, MAN Energy Solutions is committed to develop new technologies in demand by the market and our customers. Therefore, MAN Energy Solutions adjusts the development strategy towards tendencies in the shipping industry, and according to requests for new technologies from engine operators and shipowners.

Our ME-GI dual-fuel engines with direct fuel gas injection are based on the Diesel principle. Occasionally, these engines are also referred to as high-pressure dual-fuel engines because the injection pressure must be higher than the maximum combustion pressure. Therefore, the ME-GI engine type requires a fuel gas supply pressure of 300 bar.

In the LNG carrier segment, certain contemporary LNG carrier designs at the shipyards trend towards the ME-GA EGR engine and the low fuel gas supply pressure. The literature often refers to dual-fuel engines based on the premixed combustion principle as low-pressure dual-fuel engines, which relates to the relatively low fuel gas supply pressure of typically 10-16 bar.

### **ME-GA complements successful ME-GI and ME-LGI engine programme**

Today, the portfolio of MAN B&W two-stroke LNG-fuelled engines includes:

- ME-GA EGR engines targeted the LNG carrier market, with significantly reduced methane slip compared to other low-pressure engines without EGR.
- ME-GI engines with the lowest greenhouse gas (GHG) emission as a result of negligible methane slip, combined with the highest fuel efficiency on the market.

The two-stroke dual-fuel engine portfolio provides a dual-fuel solution for any vessel type and operating pattern.

### **ME-GA engine installation with advantages**

In brief, the advantages listed characterise the ME-GA engine and the installation of the engine:

- EGR-optimised tuning for improved performance and reduced methane slip (pages 9-10)
- Unique gas admission system for a safe and reliable operation (pages 11-14)
- Simple LNG supply and purging concept (pages 11, 12 and 14)
- Low FGSS maintenance costs and cost-optimised BOG-handling (pages 16-19)

- Well-known engine room design similar to ME-C, ME-GI, and ME-LGI engine room designs (page 16).

### **Future-proof solution**

When deciding on the optimal engine for new vessels, the natural tendency of shipowners is to request future-proof solutions. A decision complicated by the uncertainty over future fuel prices, and the potential taxing on CO<sub>2</sub> from fossil fuel combustion. Furthermore, the time frame for the secure availability of the different new fuels affects the decision of the shipowners.

Another future parameter that may have an increasing influence on the decision of the shipowners is the requirement to ship goods in an environmentally friendly way. Several large companies shipping their goods with respect of the environment are setting a precedent for the future.

One thing is certain though, the determination and willingness to change in the shipping industry, the maritime industry, and society in general. The journey towards a large, or even complete reduction of CO<sub>2</sub> and GHG footprints may be even shorter than set by IMO in the goals for 2030 and 2050. Hence, the current market situation is referred to by many as the “decade of action”.

## An optimised Otto principle and its characteristics

Our existing portfolio of GI and LGI dual-fuel engines spans the fuel types: methanol, LPG, LNG, ethane, and methane. These dual-fuel engines have logged more than two million service hours on alternative fuels alone. The learnings make up a vital source of invaluable experience and knowledge, and a perfect foundation for designing and developing the ME-GA engine.

A specific focus of this paper is the applied technology (EGR) for reducing the methane slip, achieving high-performance efficiency and compliance.

### Introducing the premixed Otto principle

The schematic overview in Fig. 3 shows the processes in IC engines based on the Otto cycle.

In the Otto-cycle process, scavenge air is drawn into the cylinder as the piston performs a downward expanding motion towards the bottom dead centre. Next, the gas admission valves admit fuel gas as the piston travels upwards in the cylinder. Pilot oil ignites the premixed air/fuel gas mixture, and the combustion starts.

### Differences in engine performance related to Otto and Diesel cycles

One of the engine aspects resulting from the nature of the Otto-cycle process is the limitation of engine power output compared to the Diesel-cycle engine.

As fuel gas and air mixes in the cylinder during the compression stroke, it increases the risk of misfire, and pre-ignition of the air/fuel gas mixture. The risk of pre-ignition increases when fuel gas is mixed into the entire swept volume of the engine, where the pressure and temperature can support ignition.

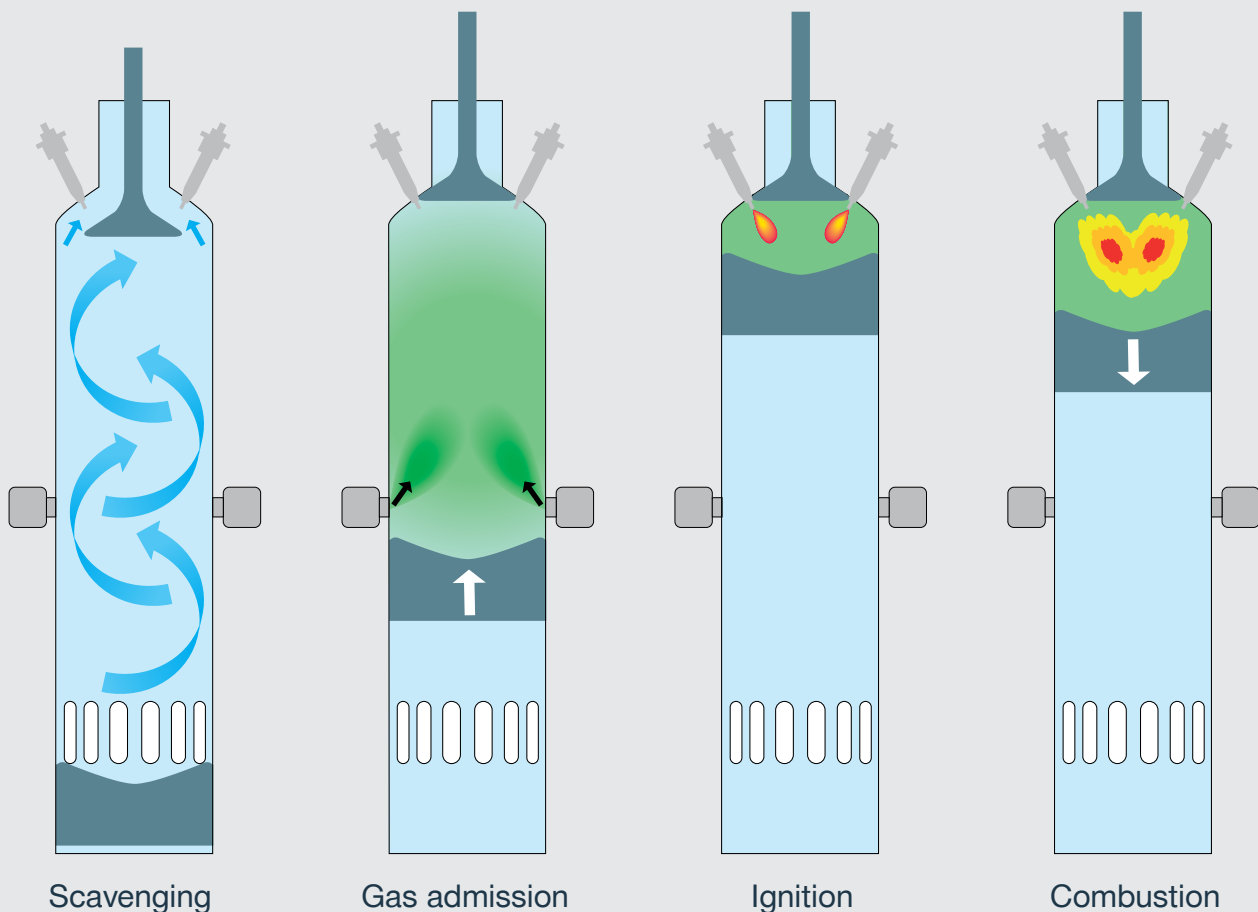

Fig. 3: Schematic representation of Otto-cycle processes

To increase the combustion stability significantly, a narrow engine-operating window can be introduced, see Fig. 4.

The operating window gives a reliable control of the combustion process and, in particular, of the air/fuel gas ratio. The window reduces the compression ratio<sup>2</sup> and the mean effective pressure to avoid pre-ignition (or knocking), which results in a lower thermal efficiency compared to the Diesel cycle.

Combustion and maximum pressures will be reduced, and, thermodynamically, this influences the maximum power output and the engine efficiency.

Furthermore, the peak temperature of the combustion is lowered, which in turn lowers the NO<sub>x</sub> formation. The NO<sub>x</sub> formation is lowered enough for the engine to become IMO Tier III compliant in dual-fuel mode without NO<sub>x</sub> abatement technology. However, for second generation Otto-cycle engines, EGR is an integral part of the engine tuning to improve performance and lower methane emissions.

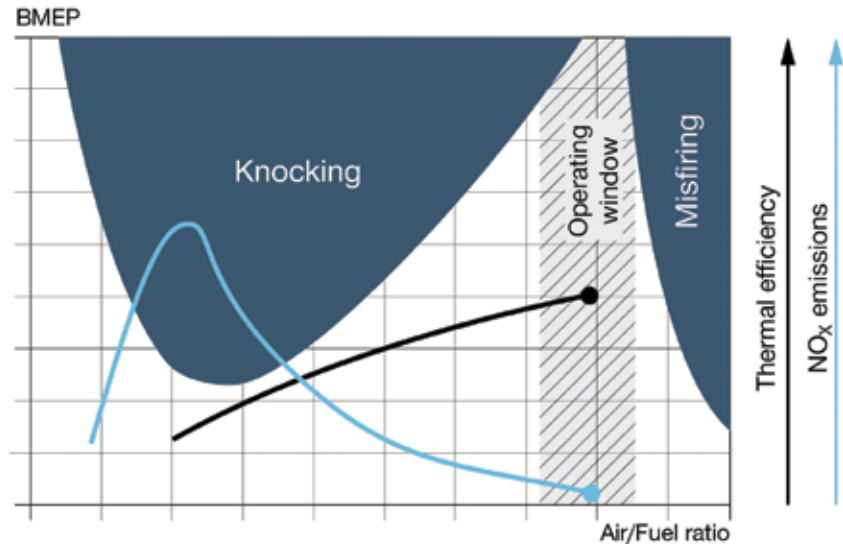

Fig. 4: Brake mean-effective pressure<sup>1</sup> (BMEP) as a function of the air/fuel gas ratio and the engine operating window

#### Definitions

- <sup>1</sup> Brake mean effective pressure (BMEP): is a theoretical parameter calculated from measured brake torque, the actual output of the internal combustion engine at the crankshaft.
- <sup>2</sup> Compression ratio: Calculate the compression ratio (CR) by the formula:  $CR = (V + C)/C$ , where V is the working volume of the cylinder, and C the total available volume in the cylinder.



## ME-GA engine development adapted to the customer

MAN Energy Solutions has developed the ME-GA EGR engine solution to accommodate the requirements of the marine market and the customers of LNG carriers.

The first engine introduced to the engine program is G70ME-C10.5-GA-EGRBP and some of the characteristic figures ( $L_i$ ) in Tier III are:

Engine type	5G70ME-C10.5-GA-EGRBP
NMCR power	14,150 kW
NMCR speed	78 r/min

### Engine configuration

MAN B&W ME-GA engines are inherently Tier III compliant in dual-fuel mode. The innovative integration of NO<sub>x</sub> abatement technology, EGR, ensures Tier III-compliant operation in fuel oil mode.

### Exhaust gas recirculation optimises engine performance

EGR has been a Tier III option for our complete engine programme for the last decade. As early as 2012, MAN Energy Solutions incorporated the first generation of EGR systems to reduce NO<sub>x</sub> emissions, and achieve Tier III compliance for the ME-C engine. Today, the number of two-stroke engines ordered with EGR are more than 500.

The foundation of our EGR design is a compact concept upstream of the turbocharger turbine, and the EGR system is mounted between the exhaust gas receiver and the scavenge air receiver. Fig. 5 shows the EGR installation on the G70ME-C10.5-GA EGR engine.

The EGR unit is designed as an integrated and compact part of the ME-GA engine. Based on our extensive experience with EGR systems, MAN Energy Solutions has specified the cooler elements, process water handling, and the blower to ensure the high availability and reliability of the whole concept.

EGR can reduce NO<sub>x</sub> formation for both Diesel- and Otto-principle engines. As described in section "Differences in engine performance related to Otto and Diesel cycles", it is not essential to



Fig. 5: EGR installation on ME-GA engine

reduce NO<sub>x</sub> formation for the Otto engine operating on fuel gas, since it is already Tier III compliant.

In the EGR process, CO<sub>2</sub> from the recirculated exhaust gas replaces part of the oxygen in the scavenge air. This replacement decreases the oxygen content, and increases the heat capacity of the scavenge air, thus reducing the temperature peak of the combustion and the formation of NO<sub>x</sub> [1].

First and foremost, EGR permits an optimisation of the performance in fuel oil mode, as NO<sub>x</sub> emissions are no longer a constraint. This is significant, because it gives the freedom to increase the compression ratio and, even more importantly, to increase the maximum pressure to the benefit of the engine efficiency.

Furthermore, there is a higher flexibility for defining the gas admission strategy.

EGR provides a number of benefits for the ME-GA engine. Most importantly, EGR has a considerable and beneficial impact on the methane slip and the level of efficiency that the engine can achieve in dual-fuel mode.

The EGR system is always active when the ME-GA engine is running. This efficiently suppresses pre-ignition, reduces excessive combustion rates caused by too rapid pressure development, and reduces the maximum heat load on combustion chamber components.

The results are:

- An improvement of the specific gas consumption by around 3% in the complete load range
- A reduction of the methane slip by around 50%.

### **Exhaust gas recirculation is integrated into the engine tuning**

For the ME-GA engine designed with an EGR system, the system is an integrated part of the engine tuning applied in all engine-running modes.

The amount of exhaust gas recirculated varies with the engine-running mode, and so does the usage of EGR consumables, for example, sodium hydroxide (NaOH). When the engine runs in liquid fuel mode, the EGR operates at its highest rate and more sulphur is present in the fuel. Therefore, NaOH consumption will be higher than in dual-fuel mode.

If you specify the engine type and rating for your specific project, MAN

Energy Solutions can provide EGR auxiliary consumption figures for NaOH, and power in a report compiled in our computerised engine application system (CEAS) [2].

Testing of EGR and the ME-GA engine running in fuel oil and dual-fuel modes has confirmed that EGR is a powerful and efficient tool for optimising the combustion process of the premixed Otto-type engine.

## The ME-GA solution

The ME-GA engine runs on natural gas (methane) in dual-fuel mode.

### Fuel gas specification

Natural gas is a hydrocarbon gas mixture consisting primarily of methane (CH<sub>4</sub>) and higher hydrocarbons like ethane and propane. The composition of the natural gas varies worldwide, but the ME-GA engine can operate on a wide range of gas qualities.

Natural gas is cooled to -162°C in a liquefaction process before it is bunkered as LNG. Due to the requirements of the liquefaction process, the composition of the hydrocarbon mixture will be within rather narrow limits. Furthermore, impurities like water (H<sub>2</sub>O), ammonia (NH<sub>3</sub>), chlorine (Cl), fluorine (F), and carbon dioxide (CO<sub>2</sub>) have been removed together with higher-order hydrocarbons.

In ship fuel tanks, LNG will change composition and properties over time. This is due to the unavoidable heat-influx from the surroundings, which will cause vaporisation of lighter compounds like nitrogen (N<sub>2</sub>) and methane. Typically, this process is described as fuel ageing, and the gas produced is referred to as boil-off gas (BOG).

Table 1 gives guiding LNG specifications for fuel bunkered for the ME-GA engine.

### Fuel supply to the engine

An FGSS delivers low-pressure gas to the engine fuel gas admission system, separated by a gas valve unit (GVU).

The ME-GA engine has two fuel oil injection systems. The main system for operation in liquid fuel mode, and a separate pilot oil system for gas mode. The pilot oil fuel is 0.5% VLSFO or MGO/MDO. The main system for operation in fuel oil mode is comparable to the system used for conventional ME-C engines. The common fuel oil supply for the two systems reduces system complexity.

A dedicated pilot valve, the micro booster injection valve (MBIV) has been developed for the ME-GA engine based on the existing fuel booster injection valve (FBIV) design known from other of our liquid fuel burning engines. The MBIV shares the fuel oil supply and preparation equipment with the main fuel oil injectors, but on the engine it is split between main injectors and pilot oil system.

The main subsystems for operation in fuel oil mode and dual-fuel mode are:

- Fuel gas supply system, and on-engine fuel gas admission components
- Main fuel system for operation in fuel oil mode, and for pilot oil supply (conventional ME fuel oil system)
- Control oil for actuation of safe gas admission valves (SGAV)
- Sealing oil to separate gas and control oil.

### Unique on-engine gas admission concept

MAN Energy Solutions has developed a unique on-engine gas admission concept for the ME-GA engine design.

About the concept:

- Double-walled gas supply pipe
- Gas-regulating unit (GRU) on engine ensures swift response to load changes and performance adjustments
- Double safety barrier with safe gas admission valves in the liner
- Robust piston ring pack with three cermet-coated piston rings, and uniform pressure drop
- Simple methane supply and purging concept minimises installation costs.

**Table 1: Guiding fuel gas specification**

Characteristic	Unit	Limit	Value
Net calorific value	MJ/Nm <sup>3</sup>	Minimum	27
Net calorific value	MJ/Nm <sup>3</sup>	Maximum	41
Methane number		Minimum	64 for 100% engine power 60 for 85% engine power
Methane	% (mol)	Minimum	70

The gas admission system enables a safe and reliable operation at lowest possible costs. The ME-GA engine features some of the most successful concept ideas from our existing dual-fuel engine platforms. The admission system on the engine contains the gas regulating unit, optimised gas piping arrangement, and safe gas admission valves in each cylinder liner.

Fig. 6 shows the major fuel gas components mounted on-engine for supplying methane to the cylinders.

1. **SGAV** installation on each side of the cylinder between the methane supply piping and the cylinder
2. **GRU** facilitates depressurisation of the system
3. **Nitrogen purge block** controls  $N_2$  purging of the inner pipe of the double-walled piping.

Methane from the FGSS passes through the main supply pipe to the GUV. From the GUV, methane is led via double-walled pipes to the GRU mounted on the engine. The GRU regulates the methane pressure to overcome the pressure in the cylinder. The engine control system (ECS) and PMI controls the regulation in accordance with performance in a fully automated process. Finally, methane is distributed to the SGAV in each cylinder and is admitted to the combustion chamber accordingly.

Each SGAV contains a window valve and a gas admission valve (GAV), see the next section about the details of the SGAV. The fuel piping is also the fuel accumulator volume. Sealing oil is supplied to the window valve and GAV to separate control oil and fuel.

Fig. 7 shows the ME-GA engine top, and the positions of the newly developed components: GRU and SGAV.

The piping design includes gas pipes with compensators that separate the cylinder units from each other in terms of gas dynamics, and act as flexible connections between engine parts.

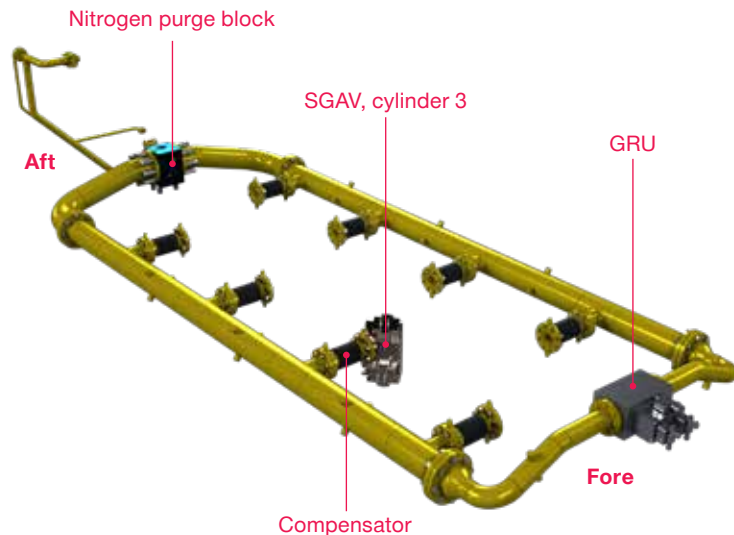

Fig. 6: Components on the ME-GA engine: Nitrogen purge block, SGAV, and GRU

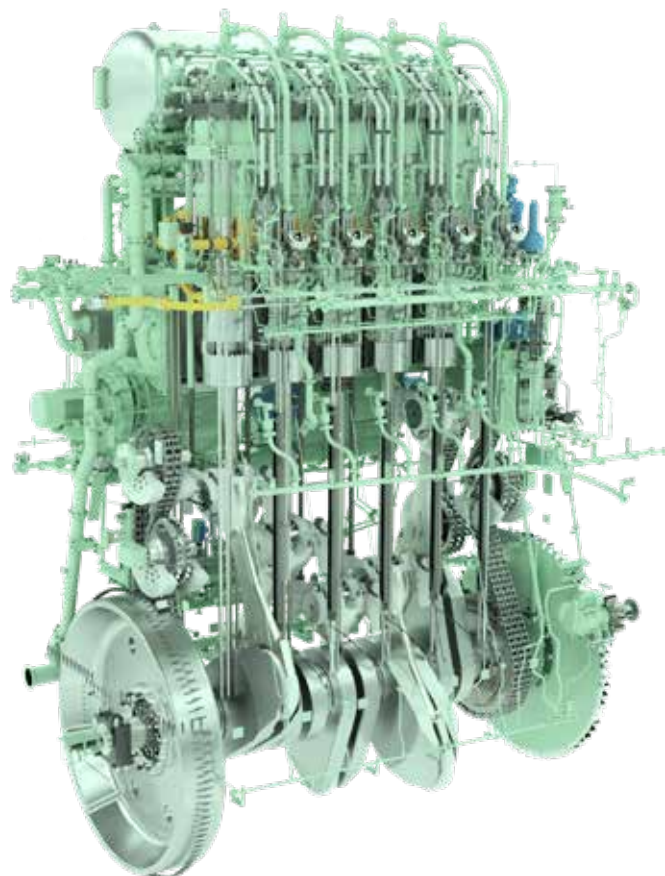

Fig. 7: ME-GA engine top with GRU, methane supply piping, and SGAV in yellow (also shown on Fig. 5)

### Safe gas admission valves

The SGAV placed in the cylinder liner was developed as a unique and simple component, see Fig. 8.

It provides both the ultimate safety against fuel gas leakage into the cylinder, and it secures optimal conditions for fuel gas admission.

- SGAV installation on engine
- Fuel gas supplied via a compensator to each SGAV (see Fig. 6)
- Maximum space for overhaul.

The SGAV is an important and decisive component in the operation of the engine. The design of the SGAV has a strong effect on air and fuel gas mixing, which affects performance, pre-ignition liability, and component temperatures.

Since the SGAV contains a window valve, and a GAV in one unit, the safety against fuel leakage into the cylinder is high, see Fig. 8.

The window valve has a couple of safety functions. It blocks the fuel gas supply to the GAV, except in a timing window where it opens and allows fuel gas to the GAV. In this way, it prevents any un-timed combustion because fuel gas admission cannot take place outside the allowed timing window.

Additionally, with the same purpose, it interlocks the hydraulic supply for actuation of the GAV.

The window valve is a cartridge type valve with spindle and spindle guide. A

spring closes the window valve, and a control valve placed on the SGAV housing actuates it.

The GAV is also a cartridge type valve forced to close by a spring. The spindle of the window valve seals tight against the seat. A separate control valve placed on the housing actuates the GAV, and the spindle is lifted from the seat.

The SGAV design gives room for easy overhaul of the valve itself along with maximum space for overhaul on the engine top.

### Gas regulating unit

The hydraulically actuated gas pressure-regulating valve was

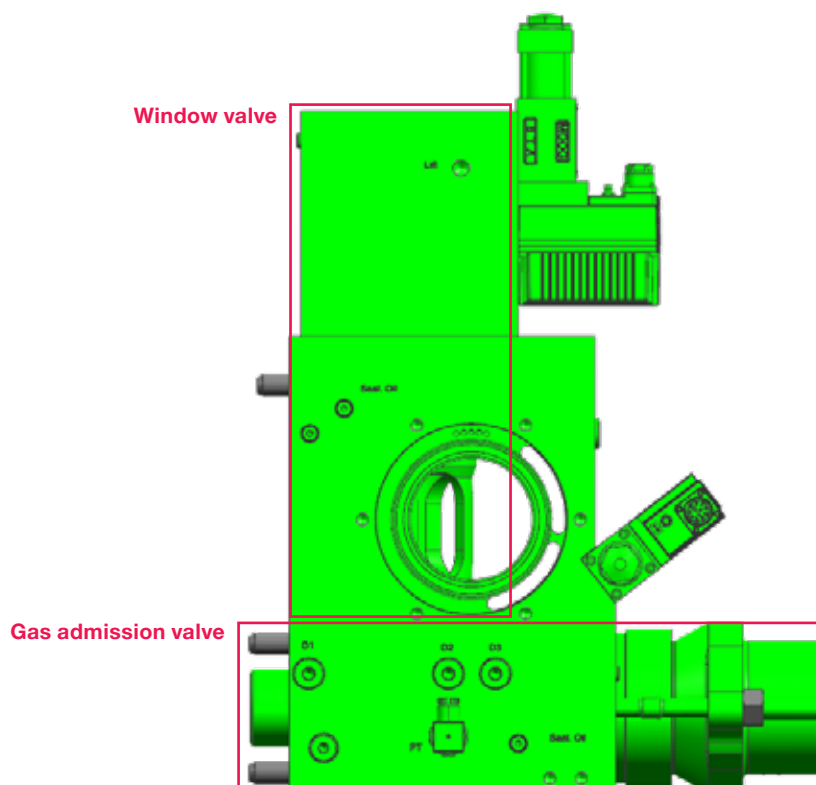

Fig. 8: SGAV with window valve and gas admission valve

developed to achieve a simple and easy installation of the ME-GA engine and the FGSS.

The ECS controls the GRU, which also simplifies the requirements for control of the supply system. The GRU ensures swift response to load changes, and performance adjustments thanks to its position on the engine close to the gas admission point. Moreover, the GRU facilitates depressurisation of the system without dedicated blow-off piping.

**Nitrogen purge block**

The safety and nitrogen purge concept from the ME-GI Mk. II engine has been adapted to the ME-GA engine with the introduction of beneficial features. Most importantly, the supply and purging concept has been designed with focus on simplicity and easy maintenance.

The release of fuel gas pressure takes place through one double-walled pipe

installation with bi-directional flow, see Fig. 9. This has eliminated the need for a dedicated purging pipe, thereby minimising installation costs.

**Fuel ratio control**

Beyond normal engine running conditions, a fuel ratio control (FRC) feature can be activated to control engine performance. An effective way of stretching the limitations for power and torque is to add liquid fuel to the combustion under such operating conditions. For that purpose, MAN Energy Solutions has developed the FRC as an integrated part of the engine control system.

Fuel gases with a low methane number as well as hot ambient conditions pose inherent challenges to the premixed gas combustion concept – in particular to the engine output power at high load in rich operating conditions, see LNG specifications in Table 1.

The following operating conditions have the highest probability for triggering FRC operation:

- Heavy acceleration.  
When engine operation is operated towards the torque limit, it can result in a mismatch between scavenge air pressure and engine load.
- Adverse weather conditions.  
These can push engine operation towards the torque limit, and it can result in a mismatch between scavenge air pressure and engine load.
- Low methane numbers resulting in knocking combustion.
- High ambient temperatures combined with high scavenge air temperatures.

The ME-GA engine is designed so that FRC activation will not occur during normal running conditions. This is possible with a pre-mixed Otto engine, because EGR is an integrated part of the combustion tuning. EGR offers

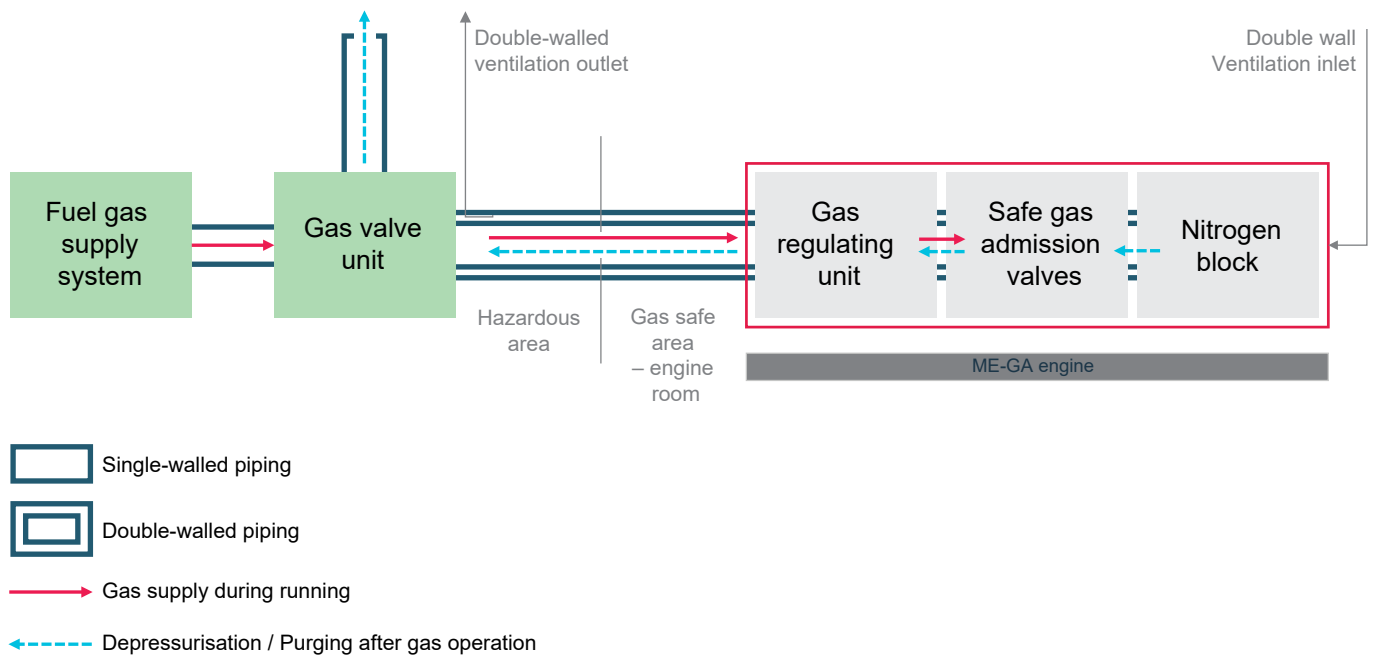

Fig. 9: Main components in the ME-GA engine fuel gas supply

many benefits when it comes to combustion stability, which in turn significantly reduces or eliminates the activation of FRC in scenarios where Otto-cycle engines without EGR activate the FRC to stabilise the combustion process.

### Piston ring package ensures even pressure distribution

The piston ring pack specified for the ME-GA engine is the well-proven three-ring pack design in Fig. 10 which has accumulated millions of running hours in service on existing G70 engines.

It is a cermet-coated ring pack designed to establish controlled surface wear, even with only slightly corroded liner walls from sulphuric acid. The open graphite structure of the liner wall is preserved, and the cylinder lubricating oil remains between the piston rings and the liner surface under all load and service

conditions. The piston ring design has pressure release grooves which distribute the pressure uniformly across the rings.

The piston crown, and piston ring performance were confirmed during the extensive testing of the ME-GA engine.

Service experience confirms that the ring pack design is robust against ring collapse, and that it reduces deposit build-up in the ring grooves. The build-up of deposits is also less dependent on the detergency of the cylinder lubricating oil. However, it is always important to use cylinder lubricating oils with high detergency levels to avoid deposit build-up, and disturbance of the piston and piston ring performance.

MAN Energy Solutions recommends the same cylinder lubricating oil strategy for the ME-GA engine as for LSFO operation [3].

Service experience has also confirmed that the designs of piston crown and piston rings give time-between-overhaul intervals that are well within our guidance values.

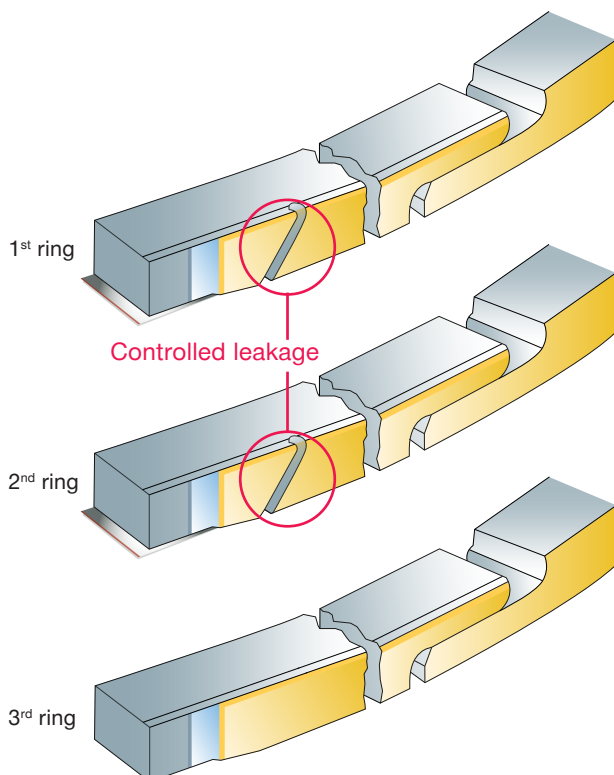

Fig. 10: Three-piston cermet-coated ring pack

## Installation aspects

The ME-GA engine has the same installation footprint as ME-C, ME-GI, and LGI engines.

### Fuel gas supply systems

The LNG tank is installed together with an FGSS supplying low-pressure methane to the ME-GA engine, and potential dual-fuel gensets.

There are three potential fuel supply solutions for the ME-GA engine:

1. BOG supply – requires a cryogenic compressor, including a cooler, to supply the required engine inlet pressure in the range of 5.5-13 barg, depending on engine load, NCV, and rating
2. LNG supply – requires a cryogenic pump and vaporiser solution
3. Compressed natural gas – requires a cryogenic compressor.

The first two solutions can be combined with a BOG reliquefaction system.

Figs. 11 and 12 show two FGSS configurations for distributing low-pressure gas to SGAVs on each cylinder on the ME-GA engine.

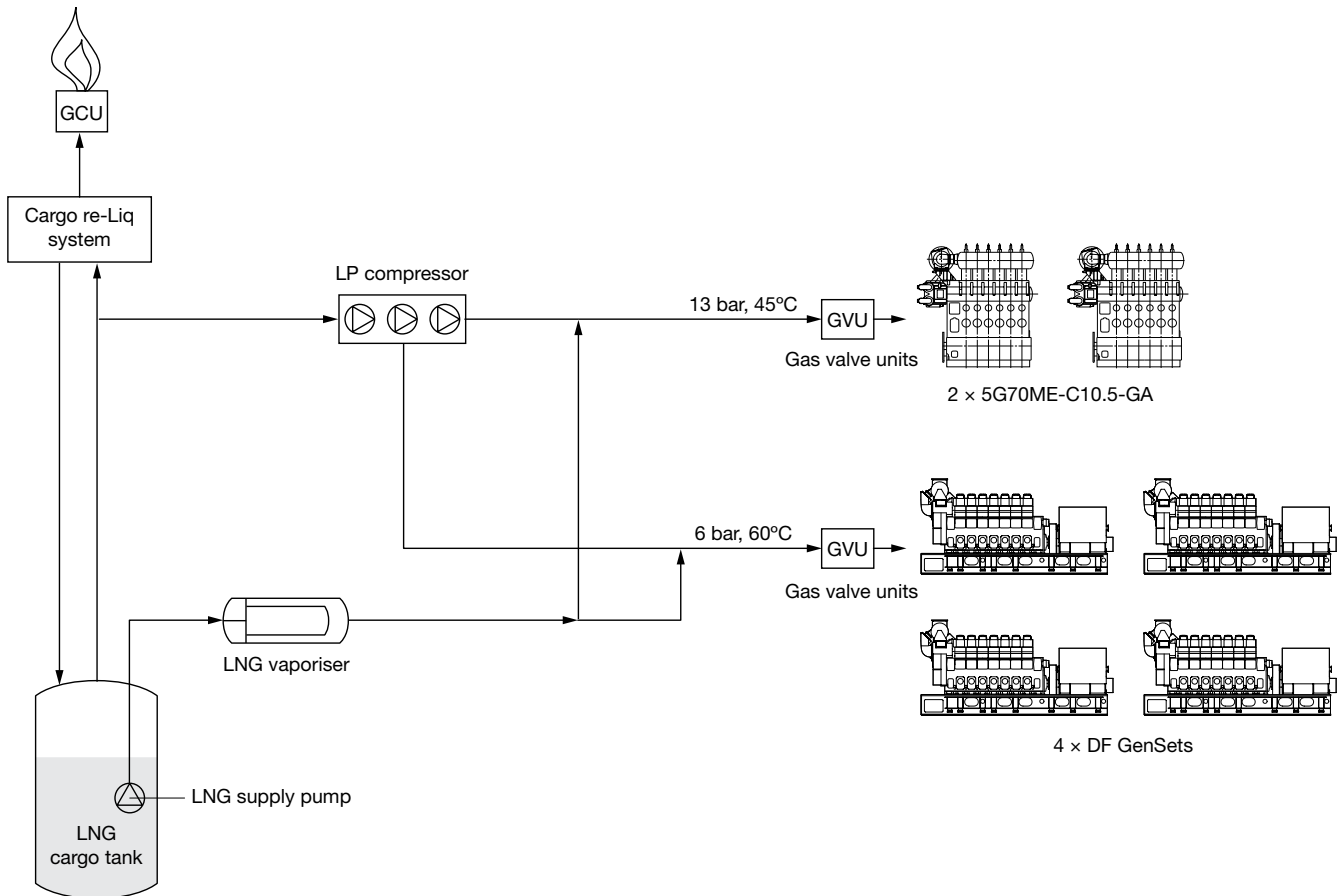

Fig. 11: FGSS configuration with LP compressor and vaporiser. Note, that the reliquefaction system configuration varies from ship design to ship design. For some contemporary LNG carrier designs, the low-pressure (LP) BOG compressor is an integral part of the reliquefaction system.



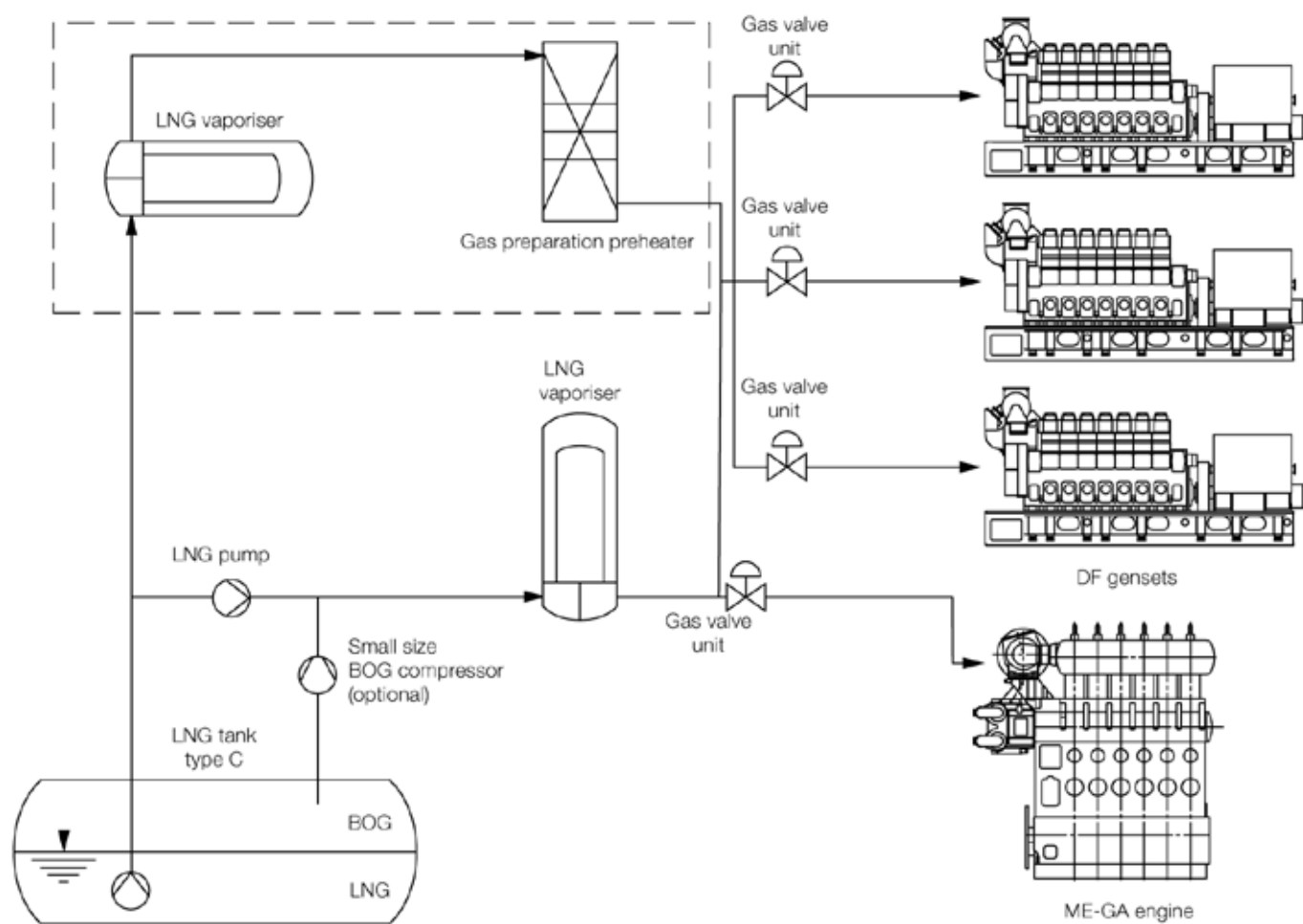

Fig. 12: FGSS configuration with cryogenic pump, small-size BOG compressor, and vaporisers

### Gas valve unit

The GUV resembles the gas valve train for the ME-GI engine. However, it has been adapted to the lower fuel supply pressure, which also represents a simplification. Fig. 6 shows the main components for fuel gas supply to the ME-GA engine, including FGSS, GUV, on-engine GRU, and SGAV.

The purpose of the GUV in Fig. 13 is to admit, stop and vent methane to the engine supply line. By placing the GUV outside the engine room, for example on deck, it is possible to have a gas-free engine room, including all pipes when ventilated. The ECS controls all functions of the GUV.



Fig. 13: Single-walled GUV from Eltronic (Courtesy of Eltronic FuelTech)

Key benefits of the GUV:

- Two different configurations:
  - single walled (Fig. 13) or
  - encapsulated
- Both configurations can be installed outside the engine room, and thereby the expensive cofferdam box in the engine room is avoided
- Flow has been optimised by installing valves that enable minimum pressure loss across the GUV
- Cost effective installation, and effortless maintenance achieved by a simple, well-engineered, and compact design.

The benefits of the GUV are all possible due to the on-engine position of the GRU, and the bypass system for depressurisation of the fuel gas system.

### Low-pressure BOG compressors

Figs. 14 – 16 show three different possibilities for small-size low-pressure BOG compressors.

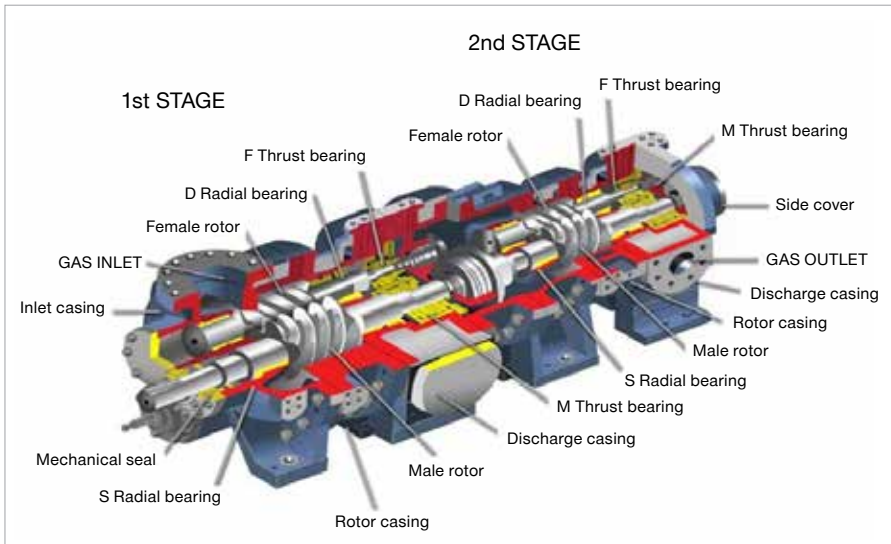

Fig. 14: BOG compressor from Kobelco (Courtesy of Kobelco)



Fig. 15: BOG compressor from Cryostar (Courtesy of Cryostar)



Fig. 16: BOG compressor from Atlas Copco (Courtesy of Atlas Copco)

## ME-GA engines and shaft generators

The Otto principle influences the capability of the ECS to maintain engine rpm stable while operating a shaft generator due to the longer delay between gas admission and ignition. The next sections address aspects to consider when combining the ME-GA engine with a shaft generator.

### PTO layout limit

Apart from a few changes, PTO layout limits for ME-GA engines and for ME-C Diesel-principle engines are similar.

The PTO layout limit in Table 2 states the allowed combined mechanical engine load from the light propeller curve (design condition) and the PTO, at any speed. The values are valid for G70ME-C10.5-GA engines. Rpm stability criteria may be a stricter limit than the difference between the light propeller curve and the PTO layout limit, compared to Diesel-cycle engines.

Designing ME-GA engines for PTO operation with high light running margins is recommended to reduce

the use of FRC caused by heavy running. A typical PTO capacity on an LNG carrier will lead to relatively high light running margins in the order of 8-10% considering the PTO layout limit.

A demonstration of 100% power for propulsion at sea trial must take place in fuel oil mode due to the speed limitations for dual-fuel mode. During a normal voyage with the PTO engaged, 100% power will not be available for propulsion since power is taken out on the PTO. Due to the PTO load, the engine will not operate on the light running propeller curve but at a higher load at the same speed. Thereby, the engine operates within an acceptable speed range for dual-fuel mode.

### Rpm/governor stability

A PTO connected to the grid via a frequency converter aims to keep a constant power output, however, this introduces negative damping as the PTO amplifies any speed disturbance. If the engine speed drops, the drive of

the PTO loads the PTO with a higher torque to keep the power constant. However, this reduces the engine speed even further.

Moreover, the nature of the premixed combustion principle entails longer time delays between gas admission and combustion (torque on the crankshaft) than for Diesel-principle engines. The time delay adds to the challenges of the ECS counteracting the instability introduced by the PTO.

MAN Energy Solutions has developed an improved interface between the ECS and the power management system (PMS) to mitigate the consequences of negative damping. The interface permits an exchange on the margin towards the load limits of the engine and actual PTO power.

The criteria for rpm stability are independent of ME-GA engine operating modes.

Contact MAN Energy Solutions at [MarineProjectEngineering2S@man-es.com](mailto:MarineProjectEngineering2S@man-es.com) for evaluations on rpm stability.

**Table 2: Speed limitations for PTO operation – G70ME-C10.5-GA**

Fuel mode	Value
Min. speed in dual-fuel and fuel-oil-only modes	50% of SMCR-speed
Max. speed in dual-fuel mode	104% of SMCR-speed
Max. speed in fuel-oil-only mode	110% of SMCR-speed <sup>1</sup>

<sup>1</sup>No more than 105% of NMCR

## Summary

MAN Energy Solutions has introduced the latest addition to the existing, successful dual-fuel engine programme [4], the dual-fuel ME-GA engine and EGR solution.

The development of the ME-GA engine, which requires only a low-pressure fuel supply, has focussed on a simple integration with some contemporary LNG carrier designs.

The two-stroke LNG-burning engine portfolio comprises:

- ME-GA engines developed for solutions with focus on competitive capex, opex, simple operation and excellent system integration with the ship and the latest energy optimisation equipment.
- Market leading ME-GI engines with the lowest greenhouse gas emission developed with focus on low opex, the preferred solution for ships using LNG as fuel.

Methane is admitted during the compression stroke in the Otto-cycle process which permits a lower supply

pressure compared to ME-GI engines. This is especially interesting for vessels with large amounts of BOG, such as LNG carriers, and can reduce the investment costs for fuel compressors substantially.

MAN Energy Solutions has extensive knowledge of, and experience with, designing and utilising exhaust gas recirculation in two-stroke engine performance. And is able to offer a matured product integrated on the engine.

Another major benefit of the EGR configuration is the potential improvement of engine performance characteristics. EGR permits an optimisation of the engine efficiency in fuel oil mode, since NO<sub>x</sub> emissions are no longer a constraint. Also in dual-fuel mode, EGR has a considerable and beneficial impact on the methane slip, and the specific gas consumption. The EGR system efficiently suppresses pre-ignition, reduces excessive combustion rates, and reduces the maximum heat load on combustion chamber components.

Unique gas admission components: Gasregulating unit, safe gas admission valves, and N<sub>2</sub> purging block were developed in-house for a safe and reliable fuel gas supply to the ME-GA engine.

The ME-GA engine is suitable for driving shaft-mounted power take-off devices with a large power output. This means that even a ship with a high power consumption, for example an LNG carrier, can be designed to trade without generators running for on-board power production.

The first ME-GA engine available in our engine programme is a 70-bore engine aimed at LNG carriers.

## Acronyms

BOG	boil-off gas
CEAS	computerised engine application system
ECS	engine control system
EGR	exhaust gas recirculation
FAT	factory acceptance test
FGSS	fuel gas supply system
FRC	fuel ratio control
GAV	gas admission valve
GHG	greenhouse gas
GCU	gas combustion unit
GRU	gas regulating unit
GVU	gas valve unit
ICE	internal combustion engine
LCV	lower calorific value
LNG	liquefied natural gas
LP	low pressure
MBIV	micro booster injection valve
PCTC	pure car truck carrier
PMS	power management system
PTO	power take off
SGAV	safe gas admission valve
SMCR	specified maximum continuous rating

## Bibliography

- [1] [Emission project guide](#)
- [2] [CEAS](#)
- [3] Service letter - [SL2020-694](#)
- [4] [Online engine programme](#)



**MAN Energy Solutions**

2450 Copenhagen SV, Denmark

P +45 33 85 11 00

F +45 33 85 10 30

info-cph@man-es.com

www.man-es.com

All data provided in this document is non-binding. This data serves informational purposes only and is not guaranteed in any way. Depending on the subsequent specific individual projects, the relevant data may be subject to changes and will be assessed and determined individually for each project. This will depend on the particular characteristics of each individual project, especially specific site and operational conditions.